

සියලු ම හිමිකම් ඇවිරිණි / முழுப் பதிப்புரிமையுடையது / All Rights Reserved

ශ්‍රී ලංකා විභාග දෙපාර්තමේන්තුව ශ්‍රී ලංකා විභාග දෙපාර්තමේන්තුව ශ්‍රී ලංකා විභාග දෙපාර්තමේන්තුව ශ්‍රී ලංකා විභාග දෙපාර්තමේන්තුව
 இலங்கைப் பரீட்சைத் திணைக்களம் இலங்கைப் பரීட்சைத் திணைக்களம் இலங்கைப் பரීட்சைத் திணைக்களம் இலங்கைப் பரීட்சைத் திணைக்களம்
 Department of Examinations, Sri Lanka Department of Examinations, Sri Lanka Department of Examinations, Sri Lanka Department of Examinations, Sri Lanka
 ශ්‍රී ලංකා විභාග දෙපාර්තමේන්තුව ශ්‍රී ලංකා විභාග දෙපාර්තමේන්තුව ශ්‍රී ලංකා විභාග දෙපාර්තමේන්තුව ශ්‍රී ලංකා විභාග දෙපාර්තමේන්තුව
 இலங்கைப் பரීட்சைத் திணைக்களம் இலங்கைப் பரීட்சைத் திணைக்களம் இலங்கைப் பரීட்சைத் திணைக்களம் இலங்கைப் பரීட்சைத் திணைக்களம்
 Department of Examinations, Sri Lanka Department of Examinations, Sri Lanka Department of Examinations, Sri Lanka Department of Examinations, Sri Lanka

අධ්‍යයන පොදු සහතික පත්‍ර (උසස් පෙළ) විභාගය, 2016 අගෝස්තු
 கல்விப் பொதுத் தராதரப் பத்திர (உயர் தர)ப் பரீட்சை, 2016 ஆகஸ்ட்
 General Certificate of Education (Adv. Level) Examination, August 2016

රසායන විද්‍යාව I
 இரசாயனவியல் I
 Chemistry I

02 E I

පැය දෙකයි
 இரண்டு மணித்தியாலம்
 Two hours

Instructions:

- * Periodic Table is provided.
- * This paper consists of 08 pages.
- * Answer all the questions.
- * Use of calculators is not allowed.
- * Write your Index Number in the space provided in the answer sheet.
- * Follow the instructions given on the back of the answer sheet carefully.
- * In each of the questions 1 to 50, pick one of the alternatives from (1), (2), (3), (4), (5) which is correct or most appropriate and mark your response on the answer sheet with a cross (x) in accordance with the instructions given on the back of the answer sheet.

$$\text{Universal gas constant } R = 8.314 \text{ J K}^{-1} \text{ mol}^{-1}$$

$$\text{Avogadro constant } N_A = 6.022 \times 10^{23} \text{ mol}^{-1}$$

$$\text{Planck's constant } h = 6.626 \times 10^{-34} \text{ J s}$$

$$\text{Velocity of light } c = 3 \times 10^8 \text{ m s}^{-1}$$

1. Green light of wave length $4.42 \times 10^{-7} \text{ m}$ is observed in the emission spectrum of hydrogen. The energy of one photon of this green light is

(1) $4.5 \times 10^{-19} \text{ kJ}$	(2) $2 \times 10^{-19} \text{ kJ}$	(3) $1.5 \times 10^{-19} \text{ kJ}$
(4) $4.5 \times 10^{-22} \text{ kJ}$	(5) $19.9 \times 10^{-26} \text{ kJ}$	
2. Which one of the following atoms in its gaseous state will liberate the largest amount of energy when it gains an electron?

(1) S	(2) P	(3) Na	(4) Mg	(5) Ne
-------	-------	--------	--------	--------
3. What is the IUPAC name of the compound X?

$$\begin{array}{c} \text{CO}_2\text{C}_2\text{H}_5 \\ | \\ \text{HC}\equiv\text{C}-\text{CH}_2-\text{C}-\text{CHO} \\ | \\ \text{CN} \end{array}$$

[X]

(1) ethyl 2-formyl-2-nitrile-4-pentynoate	(2) 2-cyano-2-ethoxycarbonyl-4-pentynal
(3) 2-ethoxycarbonyl-2-nitrile-4-pentynal	(4) ethyl-2-cyano-2-formyl-4-pentynoate
(5) ethyl 2-cyano-2-formyl-4-pentynoate	
4. Which of the following statements regarding sizes of ions formed by s and p block elements is false?

(1) Cations are always smaller than their neutral atoms.	(2) Anions are always larger than their neutral atoms.	(3) The size of cations decreases from left to right across a period.	(4) The size of anions increases from left to right across a period.
(5) The size of anions formed by elements of second period are larger than cations formed by elements of third period.			
5. The sets of quantum numbers associated with the last two electrons of an atom in an element are $(3, 0, 0, +\frac{1}{2})$ and $(3, 0, 0, -\frac{1}{2})$. The element is

(1) Li	(2) Na	(3) Mg	(4) Al	(5) K
--------	--------	--------	--------	-------

6. A 0.60 g sample of KIO_3 was dissolved in water and excess KI was added to it. The minimum amount of 3.0 mol dm^{-3} HCl required to completely convert KIO_3 to I_3^- is, (O = 16, K = 39, I = 127)
- (1) 1.0 cm^3 (2) 4.7 cm^3 (3) 5.6 cm^3 (4) 10.2 cm^3 (5) 33.6 cm^3
7. At 25°C , the solubility product, K_{sp} of MnS(s) is $5.0 \times 10^{-15} \text{ mol}^2 \text{ dm}^{-6}$. The acid dissociation constants K_1 and K_2 for $\text{H}_2\text{S(aq)}$ are $1.0 \times 10^{-7} \text{ mol dm}^{-3}$ and $1.0 \times 10^{-13} \text{ mol dm}^{-3}$ respectively. The equilibrium constant, K_c for the reaction, $\text{MnS(s)} + 2\text{H}^+(\text{aq}) \rightleftharpoons \text{Mn}^{2+}(\text{aq}) + \text{H}_2\text{S(aq)}$ is
- (1) 2.0×10^{-16} (2) 5.0×10^{-8} (3) 20 (4) 5.0×10^5 (5) 2.0×10^7
8. An organic compound A contains 39.97% of C, 6.73% of H and 53.30% of O, by weight. What is the empirical formula of A? (H = 1, C = 12, O = 16)
- (1) $\text{C}_6\text{H}_8\text{O}_2$ (2) $\text{C}_2\text{H}_4\text{O}_2$ (3) $\text{C}_3\text{H}_7\text{O}_3$ (4) $\text{C}_3\text{H}_6\text{O}_3$ (5) CH_2O
9. Which of the following statements is false with regard to the chemistry of Lithium (Li) and its compounds?
- (1) Lithium reacts with oxygen gas to give Li_2O .
 (2) Lithium has the highest melting point among the group I metals.
 (3) The basicity of LiOH is less than that of NaOH .
 (4) Li_2CO_3 has the lowest thermal stability among the group I carbonates.
 (5) LiCl gives a blue colour when subjected to the flame test.
10. The oxidation states of N^\oplus and N^\ominus in the most stable Lewis structure of the F_2NNO molecule respectively are (skeleton, $\text{F}-\overset{\text{F}}{\underset{|}{\text{N}}^\oplus}-\text{N}^\ominus-\text{O}$)
- (1) +2 and +2 (2) +1 and +3 (3) +2 and +3 (4) +1 and +2 (5) +3 and +1
11. Consider the reaction, $\text{CH}_4(\text{g}) + \text{CO}_2(\text{g}) \rightleftharpoons 2\text{CO}(\text{g}) + 2\text{H}_2(\text{g})$.
 When 0.60 mol of $\text{CH}_4(\text{g})$ and 1.00 mol of $\text{CO}_2(\text{g})$ were introduced into a closed rigid container of volume 1.00 dm^3 at 25°C and the system was allowed to reach equilibrium, 0.40 mol of $\text{CO}(\text{g})$ was formed. The value of the equilibrium constant, K_c ($\text{mol}^2 \text{ dm}^{-6}$) for the reaction is
- (1) 0.04 (2) 0.08 (3) 0.67 (4) 1.20 (5) 8.00
12. The chemical formula of diamminebromidodicarbonylhydridocobalt(III) chloride according to IUPAC rules is
- (1) $[\text{Co}(\text{CO})_2\text{BrH}(\text{NH}_3)_2]\text{Cl}$ (2) $[\text{CoBr}(\text{CO})_2(\text{NH}_3)_2\text{H}]\text{Cl}$
 (3) $[\text{Co}(\text{NH}_3)_2\text{Br}(\text{CO})_2\text{H}]\text{Cl}$ (4) $[\text{CoBr}(\text{CO})_2\text{H}(\text{NH}_3)_2]\text{Cl}$
 (5) $[\text{CoHBr}(\text{CO})_2(\text{NH}_3)_2]\text{Cl}$
13. The following procedure was used to determine the sulphur content in a coal sample. A coal sample of mass 1.60 g was burned in oxygen gas. The SO_2 gas formed was collected in a solution of H_2O_2 . This solution was then titrated with 0.10 mol dm^{-3} NaOH . The volume of NaOH required to reach the end point was 20.0 cm^3 . The percentage of sulphur in the coal sample is (S = 32)
- (1) 1.0 (2) 2.0 (3) 4.0 (4) 6.0 (5) 8.0
14. Combustion of ethylene, $\text{C}_2\text{H}_4(\text{g})$ is shown in the following reaction.
- $$\text{C}_2\text{H}_4(\text{g}) + 3\text{O}_2(\text{g}) \longrightarrow 2\text{CO}_2(\text{g}) + 2\text{H}_2\text{O}(\text{g}) \quad \Delta H = -1323 \text{ kJ mol}^{-1}$$
- What is the value of ΔH (in kJ mol^{-1}) if the combustion produces water in the liquid state, $\text{H}_2\text{O(l)}$ rather than water in the gaseous state, $\text{H}_2\text{O(g)}$? (ΔH for $\text{H}_2\text{O(g)} \longrightarrow \text{H}_2\text{O(l)}$ is -44 kJ mol^{-1})
- (1) -1235 (2) -1279 (3) -1323 (4) -1367 (5) -1411
15. The vapour pressure of benzene at 25°C is 12.5 kPa. When an unknown non-volatile substance was dissolved in 100 cm^3 of benzene at this temperature, the vapour pressure of the solution was found to be 11.25 kPa. The mole fraction of the unknown substance in the above solution is
- (1) 0.05 (2) 0.10 (3) 0.50 (4) 0.90 (5) 0.95

16. A buffer solution can be prepared by mixing a weak acid ($K_a = 4.0 \times 10^{-7} \text{ mol dm}^{-3}$) and a strong base. The ratio of the concentrations of acid to base (acid : base) needed to prepare a buffer solution at $\text{pH} = 6$ is

(1) 1 : 1 (2) 2 : 1 (3) 2 : 5 (4) 5 : 1 (5) 5 : 2

17.

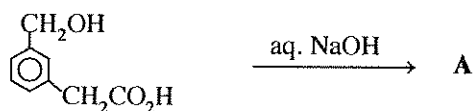

The major product **A** obtained from the reaction given above is

- (1) (2)
- (3) (4)
- (5)

18. The rate law for the reaction $\text{NO}_2(\text{g}) + \text{CO}(\text{g}) \longrightarrow \text{NO}(\text{g}) + \text{CO}_2(\text{g})$ is, $\text{Rate} = k[\text{NO}_2]^2$. If a small amount of $\text{CO}(\text{g})$ is introduced to a closed rigid container in which this reaction is taking place at a given temperature, which of the following statements is **true** regarding the changes that would take place?

- (1) Both k and reaction rate increase.
 (2) Both k and reaction rate remain unchanged.
 (3) Both k and reaction rate decrease.
 (4) k increases and reaction rate remains unchanged.
 (5) k remains unchanged and reaction rate increases.

19. At 25°C , given that.

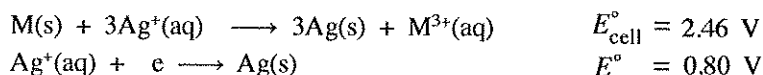

The standard reduction potential for the half-reaction, $\text{M}^{3+}(\text{aq}) + 3\text{e} \longrightarrow \text{M}(\text{s})$ at 25°C is

- (1) -1.66 V (2) -0.06 V (3) 0.06 V (4) 1.66 V (5) 3.26 V

20. How many resonance structures can be drawn for the molecule N_2O_3 ? (skeleton,)
- (1) 2 (2) 3 (3) 4 (4) 5 (5) 6

21. Which of the following statements is **true** with regard to transition metals and their compounds?

- (1) The electronic configuration of copper is $1s^2 2s^2 2p^6 3s^2 3p^6 3d^{10}$.
 (2) All elements that have d -electrons are 'transition elements'.
 (3) The electronic configuration of Ti in TiO_2 is the same as that of Sc in ScCl_3 .
 (4) Acidity of the oxides of a given transition metal decreases with increase in oxidation state of the metal ion.
 (5) Transition metals in the $3d$ series can have the quantum number $m_l = \pm 3$.

22. The equilibrium $\text{PCl}_3(\text{g}) + 3\text{NH}_3(\text{g}) \rightleftharpoons \text{P}(\text{NH}_2)_3(\text{g}) + 3\text{HCl}(\text{g})$ exists in a closed container at a constant temperature. If the volume of the container is increased by keeping the temperature constant, which of the following is **true** regarding the changes that could take place in the rates of forward and reverse reactions?

Forward reaction

- (1) increases
- (2) decreases
- (3) decreases
- (4) increases
- (5) no change

Reverse reaction

- decreases
- increases
- decreases
- increases
- no change

23. When solid ammonium chloride, $\text{NH}_4\text{Cl}(\text{s})$ is dissolved in water at 25°C , the temperature of the solution decreases. Which of the following is **true** of ΔH° and ΔS° for the process?

ΔH°

- (1) positive
- (2) positive
- (3) positive
- (4) negative
- (5) negative

ΔS°

- positive
- negative
- zero
- positive
- negative

24. Which of the following statements is **false** regarding $3d$ transition metals and their compounds?

- (1) Oxides of some metals are amphoteric.
- (2) Some metals and metal oxides are used in industry as catalysts.
- (3) Electronegativity of $3d$ transition metals is higher than $4s$ metals.
- (4) Only one element shows the oxidation state of $+7$.
- (5) Oxoions such as MnO_4^- , $\text{Cr}_2\text{O}_7^{2-}$ are resistant to reduction.

25.

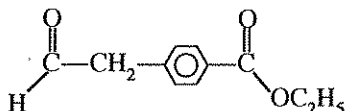

The major product obtained, when the compound above is reacted with excess CH_3MgBr , and then hydrolyzed is

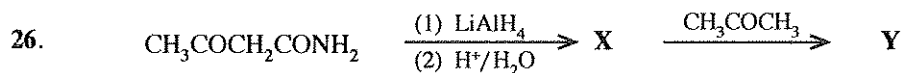
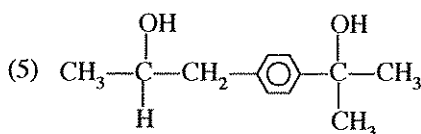
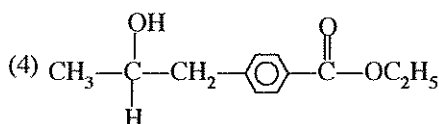
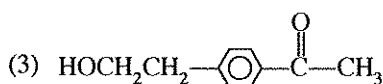
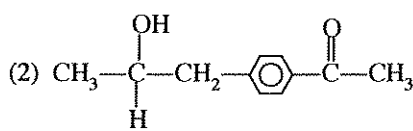
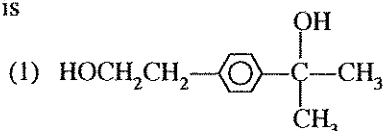

In the reaction scheme given above, the structures of **X** and **Y** respectively are

- (1) $\text{CH}_3\text{CH}(\text{OH})\text{CH}_2\text{CONH}_2$, $\text{CH}_3\text{CH}(\text{OH})\text{CH}_2\text{CON}(\text{C}(\text{CH}_3)_2)\text{CH}_3$
- (2) $\text{CH}_3\text{CH}(\text{OH})\text{CH}_2\text{CH}_2\text{NH}_2$, $\text{CH}_3\text{CH}(\text{OH})\text{CH}_2\text{CH}_2\text{N}(\text{C}(\text{CH}_3)_2)\text{CH}_3$
- (3) $\text{CH}_3\text{COCH}_2\text{CH}_2\text{NH}_2$, $\text{CH}_3\text{COCH}_2\text{CH}_2\text{N}(\text{C}(\text{CH}_3)_2)\text{CH}_3$
- (4) $\text{CH}_3\text{COCH}_2\text{CH}_2\text{NH}_2$, $\text{CH}_3\text{COCH}_2\text{CH}_2\text{NHCOCH}_3$
- (5) $\text{CH}_3\text{CH}(\text{OH})\text{CH}_2\text{CH}_2\text{NH}_2$, $\text{CH}_3\text{CH}(\text{OH})\text{CH}_2\text{CH}_2\text{NHCOCH}_3$

27. Which of the following statements is **false** with regard to NH_3 ?
- (1) NH_3 can act only as a base.
 - (2) NH_3 burns in oxygen to give N_2 gas.
 - (3) NH_3 gives a brown colour with Nessler's reagent.
 - (4) NH_3 reacts with Li to give Li_3N and H_2 gas.
 - (5) NH_3 has a bond angle less than $109^\circ 28'$ but greater than that in NF_3 .
28. An electrochemical cell was constructed using $\text{Zn}^{2+}(\text{aq})/\text{Zn}(\text{s})$ and $\text{Sn}^{2+}(\text{aq})/\text{Sn}(\text{s})$ electrodes. Which of the following statements correctly describes the operation of the cell?

$$E^\circ_{\text{Zn}^{2+}(\text{aq})/\text{Zn}(\text{s})} = -0.76 \text{ V}, \quad E^\circ_{\text{Sn}^{2+}(\text{aq})/\text{Sn}(\text{s})} = -0.14 \text{ V}$$

- (1) Zn electrode is the cathode, Zn is oxidized, electrons flow from Sn to Zn.
 - (2) Zn electrode is the cathode, Sn is oxidized, electrons flow from Sn to Zn.
 - (3) Sn electrode is the anode, $\text{Zn}^{2+}(\text{aq})$ is reduced, electrons flow from Zn to Sn.
 - (4) Zn electrode is the anode, Zn is oxidized, electrons flow from Zn to Sn.
 - (5) Zn electrode is the anode, $\text{Sn}^{2+}(\text{aq})$ is reduced, electrons flow from Sn to Zn.
29. Which one of the following statements about $\text{C}_6\text{H}_5\text{NH}_2$ is **false**?
- (1) Reacts with CH_3COCl to form an amide.
 - (2) Evolves ammonia when heated with aqueous NaOH.
 - (3) Reacts with bromine water to give a white precipitate.
 - (4) Gives a phenol when reacted with nitrous acid.
 - (5) Less basic than $\text{C}_6\text{H}_5\text{CH}_2\text{NH}_2$.
30. Four saturated solutions of silver acetate in contact with $\text{CH}_3\text{COOAg}(\text{s})$ are placed in four beakers. How does the solubility of silver acetate change, when the following solutions are added separately to each of the beakers?

CH_3COONa , dil. HNO_3 , NH_4OH , AgNO_3

	CH_3COONa	dil. HNO_3	NH_4OH	AgNO_3
(1)	increases	increases	increases	increases
(2)	decreases	decreases	decreases	decreases
(3)	decreases	increases	increases	decreases
(4)	decreases	increases	decreases	decreases
(5)	decreases	decreases	increases	decreases

- For each of the questions 31 to 40, one or more responses out of the four responses (a), (b), (c) and (d) given is/are correct. Select the correct response/responses. In accordance with the instructions given on your answer sheet, mark

- (1) if only (a) and (b) are correct.
- (2) if only (b) and (c) are correct.
- (3) if only (c) and (d) are correct.
- (4) if only (d) and (a) are correct.
- (5) if **any other** number or combination of responses is correct.

Summary of above Instructions

(1)	(2)	(3)	(4)	(5)
Only (a) and (b) are correct	Only (b) and (c) are correct	Only (c) and (d) are correct	Only (d) and (a) are correct	Any other number or combination of responses is correct

31. Consider the reaction given below.

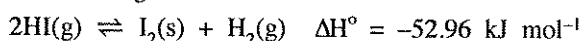

Which of the following statements is/are **correct** when the reaction takes place in a closed container?

- (a) Increasing the temperature and decreasing the pressure drives the equilibrium to the right.
- (b) Increasing the temperature and decreasing the pressure drives the equilibrium to the left.
- (c) Decreasing the temperature and increasing the pressure drives the equilibrium to the right.
- (d) Decreasing the temperature and increasing the pressure drives the equilibrium to the left.

32. Which of the following statements is/are **true** regarding the molecule $\text{CH}_2=\text{CHCHO}$?
- All three carbon atoms are sp^2 hybridized.
 - All three carbon atoms lie in a straight line.
 - All three carbon atoms do not lie in the same plane.
 - All three carbon atoms lie in the same plane.
33. Some of the reactions associated with the Solvay process are
- $\text{CaCO}_3 \xrightarrow{\Delta} \text{CaO} + \text{CO}_2$
 - $\text{NaCl} + \text{NH}_3 + \text{H}_2\text{O} + \text{CO}_2 \longrightarrow \text{NaHCO}_3 + \text{NH}_4\text{Cl}$
 - $\text{Na}_2\text{CO}_3 + \text{CO}_2 + \text{H}_2\text{O} \longrightarrow 2\text{NaHCO}_3$
 - $\text{Ca(OH)}_2 + 2\text{NH}_4\text{Cl} \longrightarrow \text{CaCl}_2 + 2\text{NH}_4\text{OH}$
34. Which of the following statements is/are always **true** regarding the rate of an elementary reaction?
- The rate can be increased by increasing temperature.
 - The rate can be increased by removing the products from the reaction medium.
 - The rate of the reaction depends on the rate of the slowest step.
 - Rate of the reaction can be increased by making $\Delta G < 0$.
35. Which of the following statements is/are **true** regarding 4-pentenal?
- Shows geometric isomerism.
 - The compound obtained when reacted with HBr does not show optical isomerism.
 - The compound obtained when reacted with HBr shows optical isomerism.
 - The compound obtained when reacted with CH_3MgBr shows optical isomerism.
36. Which of the following statements is/are **false** with regard to nitric acid?
- Pure nitric acid is a light yellow liquid.
 - All N—O bond lengths in nitric acid are equal.
 - Nitric acid cannot act as a reducing agent.
 - It is used in the manufacture of an important fertilizer, ammonium nitrate.
37. C(s) reacts with $\text{O}_2(\text{g})$ to produce 0.40 mol of $\text{CO}_2(\text{g})$, with the release of 40 kJ of heat. Which of the following statements is/are **true** for the above system? (C = 12, O = 16)
- 100 kJ of heat is required to decompose one mole of $\text{CO}_2(\text{g})$ into C(s) and $\text{O}_2(\text{g})$.
 - 25 kJ of heat is required to form 11 g of $\text{CO}_2(\text{g})$.
 - Sum of enthalpies of products is less than the sum of enthalpies of reactants.
 - Sum of enthalpies of products is greater than the sum of enthalpies of reactants.
38. Which of the following statements is/are **true** for a balanced chemical equation of an elementary reaction?
- The order of reaction is the same as molecularity.
 - The order of reaction is less than the molecularity.
 - The order of reaction is higher than the molecularity.
 - Molecularity cannot be zero.
39. Which of the following statements is/are **true** regarding the molecule given below?

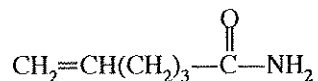

- Decolourizes bromine water.
 - Liberates ammonia when warmed with an aqueous NaOH solution.
 - Gives an orange coloured precipitate with 2,4-DNP reagent.
 - Gives a primary amine when treated with NaBH_4 .
40. Consider the compounds given below.
- | | | |
|-------------------------------------------------------------|----------------------------------------------------|-------------------------------------|
| (A) HCHO | (B) NH_2CONH_2 | (C) $\text{C}_6\text{H}_5\text{OH}$ |
| (D) $\text{HO}_2\text{C}(\text{CH}_2)_4\text{CO}_2\text{H}$ | (E) $\text{H}_2\text{N}(\text{CH}_2)_6\text{NH}_2$ | |
- Which of the pairs given below will produce thermosetting polymers when reacted under the appropriate conditions?
- A and B
 - A and C
 - C and D
 - D and E

- In question Nos. 41 to 50, two statements are given in respect of each question. From the Table given below, select the response out of the responses (1), (2), (3), (4) and (5) that best fits the two statements and mark appropriately on your answer sheet.

Response	First Statement	Second Statement
(1)	True	True, and correctly explains the first statement.
(2)	True	True, but does not explain the first statement correctly.
(3)	True	False
(4)	False	True
(5)	False	False

	First Statement	Second Statement
41.	Sucrose when treated with concentrated H_2SO_4 gives a black mass.	Concentrated H_2SO_4 is a strong oxidizing agent.
42.	In the addition reaction between $\text{CH}_3\text{CH}=\text{CH}_2$ and HX , the $\text{CH}_3\text{CH}_2\text{CH}_2^\oplus$ carbocation is formed easily as an intermediate.	Alkyl groups attached to a positively charged carbon atom release electrons through $\text{C}-\text{C}$, σ -bonds towards the positively charged carbon and increase the stability of the carbocation.
43.	The average molecular speed of $\text{H}_2(\text{g})$ at 80°C is lower than that of $\text{N}_2(\text{g})$ at 40°C .	Average molecular speed is directly proportional to the square root of temperature and inversely proportional to the square root of molar mass.
44.	Reactivity of alkali metals with water increases on going down the group.	Strong metallic bonds are formed when the size of the metal atom increases.
45.	$\text{CH}_3\text{C}\equiv\text{CH}$ gives a red precipitate when treated with ammoniacal Cu_2Cl_2 .	The acidic terminal hydrogen in alkynes can be displaced by metals.
46.	All spontaneous reactions are exothermic.	For any reaction $\Delta G = \Delta H + T\Delta S$
47.	The reaction between $\text{N}_2(\text{g})$ and $\text{H}_2(\text{g})$ to produce $\text{NH}_3(\text{g})$ is endothermic.	$\text{NH}_3(\text{g})$ is used in the synthesis of nitric acid and urea.
48.	Mirror images of bromochloromethane are enantiomers.	Enantiomers are non superimposable mirror images of each other.
49.	The solubility of barium oxalate, $\text{BaC}_2\text{O}_4(\text{s})$ is less in acidic aqueous medium than in water.	The conjugate acid of $\text{C}_2\text{O}_4^{2-}$ is the weak acid $\text{H}_2\text{C}_2\text{O}_4$.
50.	Enzymes present in root nodules of certain plants are capable of fixing N_2 .	N_2 molecule is unreactive mainly because of the presence of the $\text{N}-\text{N}$ triple bond.

* * *

සියලු ම හිමිකම් ඇවිරිණි / முழுப் பதிப்புரிமையுடையது / All Rights Reserved

ශ්‍රී ලංකා විභාග දෙපාර්තමේන්තුව ශ්‍රී ලංකා විභාග දෙපාර්තමේන්තුව ශ්‍රී ලංකා විභාග දෙපාර්තමේන්තුව ශ්‍රී ලංකා විභාග දෙපාර්තමේන්තුව ශ්‍රී ලංකා විභාග දෙපාර්තමේන්තුව
 இலங்கைப் பரீட்சைத் திணைக்களம் இலங்கைப் பரීட்சைத் திணைக்களம் இலங்கைப் பரීட்சைத் திணைக்களம் இலங்கைப் பரීட்சைத் திணைக்களம் இலங்கைப் பரීட்சைத் திணைக்களம்
 Department of Examinations, Sri Lanka Department of Examinations, Sri Lanka Department of Examinations, Sri Lanka Department of Examinations, Sri Lanka Department of Examinations, Sri Lanka
 இலங்கைப் பரීட்சைத் திணைக்களம் இலங்கைப் பரීட்சைத் திணைக்களம் இலங்கைப் பரීட்சைத் திணைக்களம் இலங்கைப் பரීட்சைத் திணைக்களம் இலங்கைப் பரීட்சைத் திணைக்களம்
 Department of Examinations, Sri Lanka Department of Examinations, Sri Lanka Department of Examinations, Sri Lanka Department of Examinations, Sri Lanka Department of Examinations, Sri Lanka

අධ්‍යයන පොදු සහතික පත්‍ර (උසස් පෙළ) විභාගය, 2016 අගෝස්තු
 கல்விப் பொதுத் தராதரப் பத்திர (உயர் தர)ப் பரீட்சை, 2016 ஓகஸ்ட்
 General Certificate of Education (Adv. Level) Examination, August 2016

රසායන විද්‍යාව H
 இரசாயனவியல் H
 Chemistry II

02 E II

පැය තුනයි
 மூன்று மணித்தியாலம்
 Three hours

Index No. :

- * A Periodic Table is provided on page 15.
- * Use of calculators is not allowed.
- * Universal gas constant, $R = 8.314 \text{ J K}^{-1} \text{ mol}^{-1}$
- * Avogadro constant, $N_A = 6.022 \times 10^{23} \text{ mol}^{-1}$
- * In answering this paper, you may represent alkyl groups in a condensed manner.

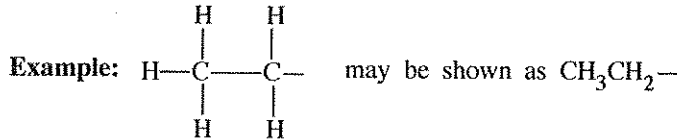

□ PART A — Structured Essay (pages 2 - 8)

- * Answer all the questions on the question paper itself.
- * Write your answer in the space provided for each question. Please note that the space provided is sufficient for the answer and that extensive answers are not expected.

□ PART B and PART C — Essay (pages 9 - 14)

- * Answer four questions selecting two questions from each part. Use the papers supplied for this purpose.
- * At the end of the time allotted for this paper, tie the answers to the three Parts A, B and C together so that Part A is on top and hand them over to the Supervisor.
- * You are permitted to remove only Parts B and C of the question paper from the Examination Hall.

For Examiner's Use Only

Part	Question No.	Marks
A	1	
	2	
	3	
	4	
B	5	
	6	
	7	
C	8	
	9	
	10	
Total		
Percentage		

Final Mark

In Numbers	
In Letters	

Code Numbers

Marking Examiner 1	
Marking Examiner 2	
Checked by :	
Supervised by :	

PART A — STRUCTURED ESSAY

Answer all four questions on this paper itself. (Each question carries 10 marks.)

Do not write in this column.

1. (a) You are provided with the following list of some
- p*
- block elements in the Periodic Table.

B	C	N	O	F	Ne
Al	Si	P	S	Cl	Ar

From the list,

- (i) identify the non-metallic element that forms a homoatomic covalent lattice of high hardness.
- (ii) identify the element that exhibits the widest range of oxidation states.
- (iii) identify the element that has the highest first ionization energy.
- (iv) identify the element that exhibits amphoteric properties.
- (v) identify the element that has two gaseous allotropes.
- (vi) identify the element that is considered to be the strongest oxidizing agent.
- (2A marks)

- (b) The following parts (i) to (v) are based on the molecule
- CN_4
- . It has the following skeleton.

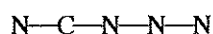

- (i) Assuming that N—N bond lengths are approximately equal, draw the **most acceptable** Lewis structure for this molecule.
- (ii) Draw **three** resonance structures for this molecule (excluding the structure drawn in part (i) above).
- (iii) Based on the Lewis structure drawn in (i) above, state the following regarding the C and N atoms given in the table below.
- | | |
|---------------------------------|---------------------------------------------|
| I. VSEPR pairs around the atom. | II. electron pair geometry around the atom. |
| III. shape around the atom. | IV. hybridization of the atom. |

The nitrogen atoms of CN_4 are numbered as follows:

	C	N ²	N ³
I. VSEPR pairs			
II. electron pair geometry			
III. shape			
IV. hybridization			

[see page three]

- (iv) In the Lewis structure drawn in part (i) above, indicate whether N^2 or N^3 has the **higher** electronegativity. Give reasons for your choice. [Numbering of atoms is as in part (iii).]

.....

- (v) Identify the atomic/hybrid orbitals involved in the formation of the following σ bonds in the Lewis structure drawn in part (i) above. [Numbering of atoms is as in part (iii).]

- I. N^1-C N^1, C.....
 II. $C-N^2$ C....., N^2
 III. N^2-N^3 N^2, N^3
 IV. N^3-N^4 N^3, N^4

(5.6 marks)

- (c) State whether the following statements are **true** or **false**. (Reasons are **not** required.)

- (i) SF_6 and OF_6 are both stable molecules.
 (ii) Although the electron pair geometry of $SiCl_4$, NCl_3 and SCl_2 is tetrahedral, their bond angles are different.
 (iii) The boiling point of Kr is greater than that of Xe.
 (iv) The solubility of group II sulphates decreases down the group primarily due to decrease in hydration enthalpy of the cations.

(2.0 marks)

2. (a) **X** and **Y** are *s*-block elements of the Periodic Table. They react with water to form hydroxides. The hydroxide of **X** is more basic than that of **Y**. The hydroxide of **X** is used in the manufacture of baby soap. The hydroxide of **Y** is commonly used to identify the gas **Z** that is one of the main gases responsible for global warming.

- (i) Identify **X** and **Y**.

X **Y**

- (ii) Write the electronic configurations of **X** and **Y**.

X =
Y =

- (iii) Write the colour of the flame given by salts of **X** and **Y** in the flame test.

X = **Y** =

- (iv) Indicate the relative magnitudes of the following in respect of **X** and **Y**.

- I. Atomic size >
 II. Density >
 III. Melting point >
 IV. First ionization energy >

- (v) Identify **Z**.

.....

Do not
write
in this
column.

100

Do not
write
in this
column.

(vi) Using balanced chemical equations **only**, indicate how the hydroxide of **Y** could be used to identify **Z**.

Note: Indicate precipitates, if any, using “↓” and colours of precipitates/solutions used in the identification.

.....

(vii) A natural source of **Y** in which it is present as a carbonate is used as a raw material in the manufacture of a disinfectant.

I. Name the natural source.

II. Identify the disinfectant.

III. Write the steps in the manufacturing process of the disinfectant, using balanced chemical equations **only**.

.....

(5.0 marks)

(b) (i) Complete the reactions given below by selecting the appropriate solution from the given list and writing in the box.

List of solutions (not in order)

$\text{Na}_2\text{S}_2\text{O}_3(\text{aq})$, $\text{AgNO}_3(\text{aq})$, $\text{K}_2\text{SO}_4(\text{aq})$, $(\text{NH}_4)_2\text{CO}_3(\text{aq})$, $\text{BaCl}_2(\text{aq})$, $\text{KI}(\text{aq})$

Note: A solution should be used **only once**.

I. $\text{BaCl}_2(\text{aq}) + \boxed{\phantom{\text{Na}_2\text{S}_2\text{O}_3(\text{aq})}} \longrightarrow \text{A}$ (White precipitate that dissolves in dil. HCl to give a clear solution)

II. $\text{Pb}(\text{NO}_3)_2(\text{aq}) + \boxed{\phantom{\text{AgNO}_3(\text{aq})}} \longrightarrow \text{B}$ (Yellow precipitate that dissolves in hot water)

III. $\text{AgNO}_3(\text{aq}) + \boxed{\phantom{\text{K}_2\text{SO}_4(\text{aq})}} \longrightarrow \text{C}$ (White precipitate that turns black on standing)

IV. $\text{K}_2\text{SO}_3(\text{aq}) + \boxed{\phantom{(\text{NH}_4)_2\text{CO}_3(\text{aq})}} \longrightarrow \text{D}$ (White precipitate that dissolves in dil. HCl)

V. $\text{NaBr}(\text{aq}) + \boxed{\phantom{\text{BaCl}_2(\text{aq})}} \longrightarrow \text{E}$ (Pale yellow precipitate that dissolves completely in conc. ammonia)

VI. $\text{Ba}(\text{NO}_3)_2(\text{aq}) + \boxed{\phantom{\text{KI}(\text{aq})}} \longrightarrow \text{F}$ (White precipitate that does **not** dissolve in dil. HCl)

(ii) Write the chemical formulae of the precipitates **A** to **F**.

A **B**

C **D**

E **F**

(iii) Write balanced chemical equations for the dissolution of precipitates **A**, **D** and **E** in (b)(i) above.

.....

(5.0 marks)

100

[see page five]

Do not write in this column.

3. (a) When 0.010 moles of gas A is placed in a 1.0 dm³ evacuated closed rigid container in the presence of a small amount of a solid catalyst, at 227 °C, it decomposes as shown below.

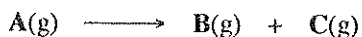

The concentration of A(g) was measured over time. The results are shown in the following graph.

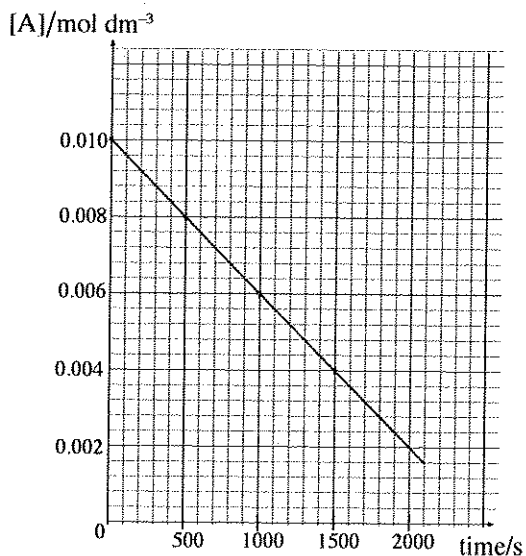

- (i) Taking the order and the rate constant of the reaction as **a** and **k**, respectively, write the rate expression for the above reaction.

.....

- (ii) Giving reasons, determine the value of **a**.

.....

- (iii) Calculate the rate constant, **k** at 227 °C.

.....

- (iv) Calculate the pressure in the container when half the initial amount of A(g) has decomposed. Assume that the volume of the catalyst can be neglected.

.....

(6.0 marks)

- (b) In the presence of a solid catalyst, the gas **X** decomposes according to the following chemical equation.

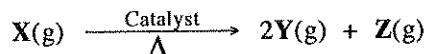

1.0 mole of gas **X** was introduced to an evacuated container. The initial volume of the gas was measured to be V_0 . The reaction was initiated by introducing a small amount of catalyst (volume is negligible). The rate constant of the catalysed reaction is k_1 and order of the reaction with respect to **X** is **b**. The initial rate of the reaction was measured as R_0 . The pressure of the system was maintained at a constant value by allowing the container to expand. The temperature of the system was also maintained at a constant value.

- (i) Write an expression for R_0 using the terms **b**, k_1 and V_0 .

.....

- (ii) It was observed that the rate of the reaction was $0.25R_0$ and the volume of the container was doubled when 50% of **X(g)** was consumed. Calculate the order **b** of the reaction.

.....

(4.0 marks)

Do not
write
in this
column.

100

Do not
write
in this
column.

4. (a) (i) **A, B, C** and **D** are structural isomers with the molecular formula $C_4H_{10}O$. All four isomers reacted with metallic sodium to evolve H_2 gas. Of the four isomers, only **A** exhibited optical isomerism. When **B, C** and **D** were added separately to conc. HCl , containing $ZnCl_2$, the mixture containing **B** became turbid very rapidly. The development of turbidity with **C** and **D** was very slow. When **C** and **D** were heated with conc. H_2SO_4 , **E** and **F** were respectively obtained. **E** and **F** are structural isomers with the molecular formula C_4H_8 . Neither **E** nor **F** exhibited geometric isomerism. When **E** and **F** were treated with HBr , **G** and **H** were respectively obtained. Only **G** exhibited optical isomerism. Draw the structures of **A, B, C, D, E, F, G** and **H** in the boxes given below. (It is **not necessary** to draw stereoisomeric forms.)

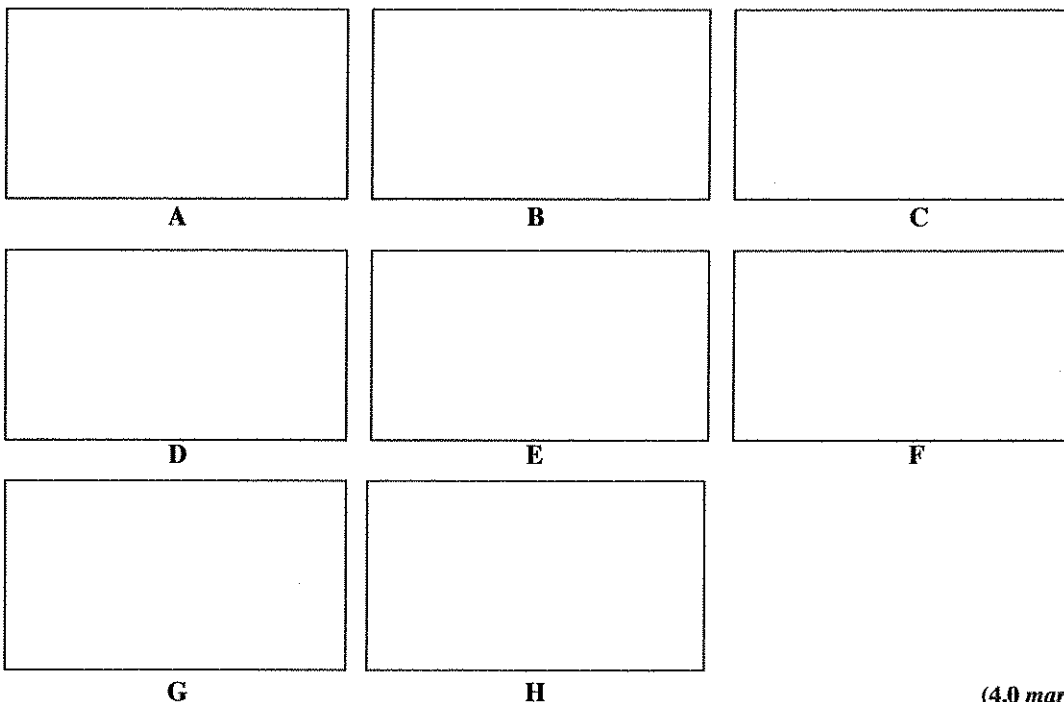

(4.0 marks)

- (ii) When **A** and **C** were reacted with PCC, **I** and **J** were respectively obtained. Draw the structures of **I** and **J** in the boxes given below. (PCC = Pyridinium chlorochromate)

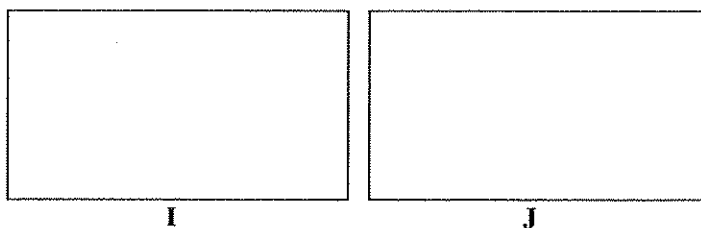

(1.0 mark)

- (b) Draw the structure of the **major** organic products **K, L, M, N, O, P, Q, R, S** and **T** of the following reactions in the relevant boxes given on page 8.

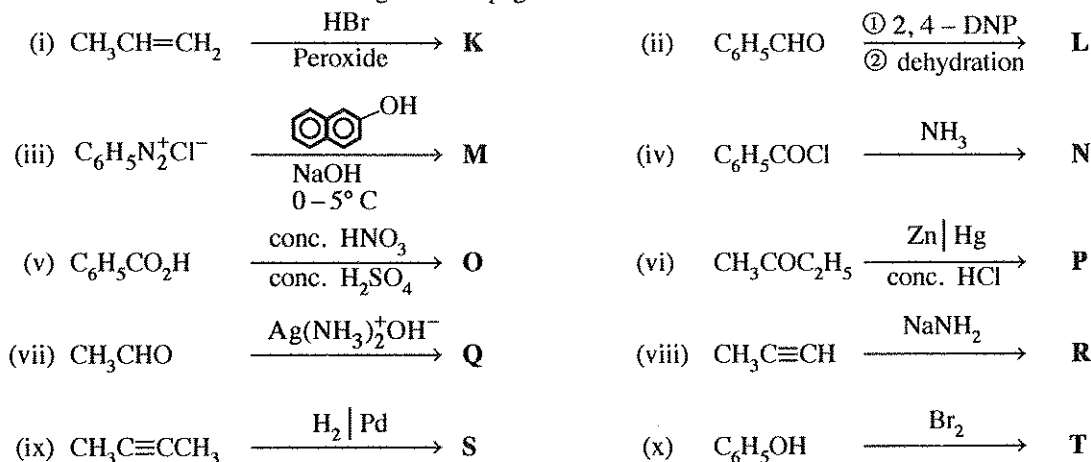

[see page eight]

Do not
write
in this
column.

K

L

M

N

O

P

Q

R

S

T

(3.0 marks)

(c) Write the mechanism for the reaction between $C_2H_5CH=CHC_2H_5$ and $Br_2(CCl_4)$.

(2.0 marks)

100

* *

[see page nine]

සියලු ම හිමිකම් ඇවිරිණි / முழுப் பதிப்புரிமையுடையது / All Rights Reserved

ශ්‍රී ලංකා විභාග දෙපාර්තමේන්තුව ශ්‍රී ලංකා විභාග දෙපාර්තමේන්තුව ශ්‍රී ලංකා විභාග දෙපාර්තමේන්තුව ශ්‍රී ලංකා විභාග දෙපාර්තමේන්තුව ශ්‍රී ලංකා විභාග දෙපාර්තමේන්තුව
 இலங்கைப் பரீட்சைத் திணைக்களம் இலங்கைப் பரීட்சைத் திணைக்களம் இலங்கைப் பரීட்சைத் திணைக்களம் இலங்கைப் பரීட்சைத் திணைக்களம் இலங்கைப் பரීட்சைத் திணைக்களம்
 Department of Examinations, Sri Lanka Department of Examinations, Sri Lanka Department of Examinations, Sri Lanka Department of Examinations, Sri Lanka Department of Examinations, Sri Lanka
 இலங்கைப் பரීட்சைத் திணைக்களம் இலங்கைப் பரීட்சைத் திணைக்களம் இலங்கைப் பரීட்சைத் திணைக்களம் இலங்கைப் பரීட்சைத் திணைக்களம் இலங்கைப் பரීட்சைத் திணைக்களம்
 Department of Examinations, Sri Lanka Department of Examinations, Sri Lanka Department of Examinations, Sri Lanka Department of Examinations, Sri Lanka Department of Examinations, Sri Lanka

අධ්‍යයන පොදු සහතික පත්‍ර (උසස් පෙළ) විභාගය, 2016 අගෝස්තු
 கல்விப் பொதுத் தராதரப் பத்திர (உயர் தர)ப் பரீட்சை, 2016 ஓகஸ்ட்
 General Certificate of Education (Adv. Level) Examination, August 2016

රසායන විද්‍යාව II
 இரசாயனவியல் II
 Chemistry II

02 E II

* Universal gas constant $R = 8.314 \text{ J K}^{-1} \text{ mol}^{-1}$

* Avogadro constant $N_A = 6.022 \times 10^{23} \text{ mol}^{-1}$

PART B – ESSAY

Answer two questions only. (Each question carries 15 marks.)

5. (a) The procedure given below was followed to determine the partition coefficient, K_D of butanedioic acid (BDA, $\text{HOOCCH}_2\text{CH}_2\text{COOH}$) between ether and water at 25°C .

Initially, 20 g of solid BDA was shaken well with a mixture of approximate volumes of 100 cm^3 of ether and 100 cm^3 of water in a reagent bottle and the layers were allowed to separate. At this stage, some undissolved BDA was seen remaining at the bottom of the reagent bottle. Thereafter, a 50.00 cm^3 volume of ether layer and a 25.00 cm^3 volume of water layer were titrated with 0.05 mol dm^{-3} NaOH solution. The volumes taken from the ether and water layers required 4.80 cm^3 and 16.00 cm^3 of the NaOH solution respectively.

- (i) Calculate the partition coefficient, K_D for the distribution of butanedioic acid between ether and water at 25°C .
 (ii) Calculate the solubility of butanedioic acid in ether, given that the solubility of this acid in water is 8.0 g dm^{-3} . (4.0 marks)

- (b) Consider the following reactions. Thermodynamic data supplied are **not** for the standard state.

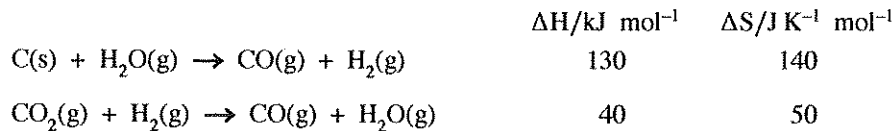

- (i) Calculate ΔH and ΔS for the reaction $2\text{CO(g)} \rightarrow \text{C(s)} + \text{CO}_2\text{(g)}$. State giving reasons whether the sign of ΔS agrees with the reaction taking place.
 (ii) By means of a suitable calculation, predict whether the reaction given in part (i) above is spontaneous at 27°C . (4.0 marks)

- (c) An excess amount of C(s) and 0.15 mol of $\text{CO}_2\text{(g)}$ were placed in a closed rigid 2.0 dm^3 container and the system was allowed to reach equilibrium at a temperature of 689°C . Once the equilibrium was achieved, the pressure in the container was found to be $8.0 \times 10^5 \text{ Pa}$. (Take $RT = 8000 \text{ J mol}^{-1}$ at 689°C)

- (i) Write an expression for the equilibrium constant, K_p for the reaction $\text{C(s)} + \text{CO}_2\text{(g)} \rightleftharpoons 2\text{CO(g)}$.
 (ii) Calculate K_p and K_c at 689°C .
 (iii) In another experiment, the container described above contains an excess of C(s) together with CO(g) and $\text{CO}_2\text{(g)}$ at 689°C . The initial partial pressure of each gas is $2.0 \times 10^5 \text{ Pa}$. Explain, with the aid of a calculation, the change in partial pressure of $\text{CO}_2\text{(g)}$ when the system reaches equilibrium. (7.0 marks)

6. (a) A 0.10 mol dm^{-3} solution of a weak acid, **HA** was prepared by diluting an appropriate amount of the pure weak acid to 25.00 cm^3 with distilled water in a volumetric flask at 25°C . The pH of this solution was 3.0.

- Considering the equation, $\text{HA}(\text{aq}) + \text{H}_2\text{O}(\text{l}) \rightleftharpoons \text{H}_3\text{O}^+(\text{aq}) + \text{A}^-(\text{aq})$, calculate the dissociation constant, K_a of the weak acid.
- A dilute solution of this weak acid, **HA** was titrated with a strong base, **BOH**. It was found that the pH of the titration mixture after reaching the equivalence point was 9.0. Calculate the concentration of the salt, **AB** in the titration mixture. ($K_w = 1.0 \times 10^{-14} \text{ mol}^2 \text{ dm}^{-6}$ at 25°C)
- The above titration mixture was diluted hundred times by adding distilled water. Calculate the pH of the diluted titration mixture.

(5.0 marks)

(b) $\text{AgBr}(\text{s})$ is a pale-yellow coloured salt sparingly soluble in water.

Its solubility product, K_{sp} is $5.0 \times 10^{-13} \text{ mol}^2 \text{ dm}^{-6}$ at 25°C .

- Calculate the concentration of $\text{Ag}^+(\text{aq})$ in a saturated solution of AgBr in equilibrium with solid AgBr at 25°C .
- Solid AgBr together with 100.0 cm^3 of the solution described in part (i) above were placed in a beaker. A volume of 100.0 cm^3 of distilled water was added to the beaker and the mixture was stirred well until the equilibrium is reached. At this stage, some solid AgBr was still left at the bottom of the beaker. What could be the concentration of $\text{Ag}^+(\text{aq})$ in this solution? Explain your answer.
- Using a suitable calculation, predict the observation expected when 10.0 cm^3 of a $1.5 \times 10^{-4} \text{ mol dm}^{-3}$ AgNO_3 solution and 5.0 cm^3 of a $6.0 \times 10^{-4} \text{ mol dm}^{-3}$ NaBr solution are mixed at 25°C .

(5.0 marks)

(c) (i) The pressure of the vapour phase in equilibrium with an ideal binary solution is P . The liquid phase mole fractions of the two components are X_1 and X_2 , and their respective saturated vapour pressures are P_1^0 and P_2^0 . Show that

$$X_1 = \frac{P - P_2^0}{P_1^0 - P_2^0}$$

- The pressure of the vapour phase in equilibrium with a binary solution containing methanol and ethanol is $4.5 \times 10^4 \text{ Pa}$ at 50°C . At this temperature the saturated vapour pressures of methanol and ethanol are $5.5 \times 10^4 \text{ Pa}$ and $3.0 \times 10^4 \text{ Pa}$ respectively. Consider that the solutions behave ideally.
 - Calculate the mole fractions of methanol and ethanol in the liquid phase.
 - Calculate the mole fractions of methanol and ethanol in the vapour phase.
- Based on the above calculations and given information, draw the vapour pressure - composition diagram of the methanol - ethanol mixture at 50°C . Consider that the solutions behave ideally.

(5.0 marks)

7. (a) Using **only** the chemicals given in the list, show how you would carry out the following conversion.

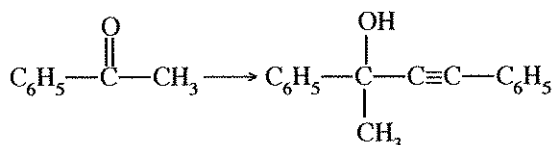

List of chemicals

H_2O , alcoholic KOH , Br_2 , Conc. H_2SO_4 ,
 NaBH_4 , $\text{C}_2\text{H}_5\text{MgBr}$ /dry ether

Your conversion should not exceed 9 steps.

(6.0 marks)

(b) Identify $R_1 - R_6$ and $X_1 - X_5$ in order to complete the following reaction scheme.

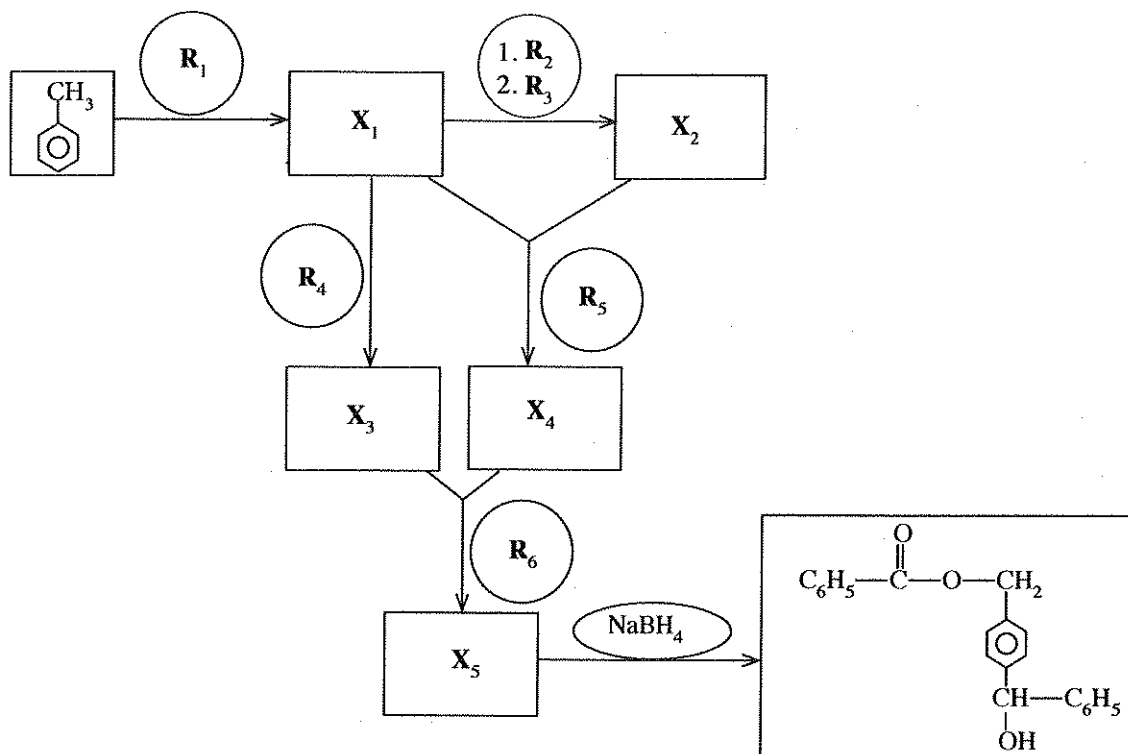

(7.0 marks)

(c) (i) Give the mechanism for the following reaction.

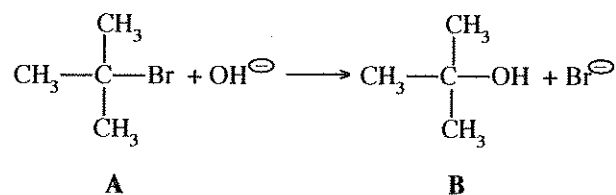

(ii) The reaction of **A** with NaOH, gives in addition to **B** another product **C**. Give the structure of **C**.

(2.0 marks)

PART C — ESSAY

Answer two questions only. (Each question carries 15 marks.)

8. (a) The compound **A** ($A = MX_n$, $M =$ a transition element that belongs to the $3d$ -block, $X =$ ligands of the same type) when treated with excess dilute NaOH followed by H_2O_2 gives a compound **B**. When an aqueous solution of **B** is acidified with dil. H_2SO_4 compound **C** is produced. **C** when reacted with NH_4Cl gives compound **D** as one of the products. Heating solid **D** gives a blue coloured compound **E**, water vapour and an inert diatomic gas **F**. Ca metal when burnt in gas **F** gives a white solid **G**. The reaction of **G** with water liberates a gas **H**. This gas forms white fumes with HCl gas. The metal Na reacts with liquid **H** to give a colourless diatomic gas **I** as one of the products. When an aqueous solution of **A** is treated with excess Na_2CO_3 , a coloured precipitate is formed. The precipitate is filtered and the filtrate is acidified with dil HNO_3 . Addition of $AgNO_3(aq)$ to this solution gives a white precipitate which is soluble in dilute NH_4OH .

(i) Identify **A**, **B**, **C**, **D**, **E**, **F**, **G**, **H** and **I**.

(ii) What will you observe when a solution containing **C** is treated with dil. NaOH? Give the balanced chemical equation relevant to this observation.

(5.0 marks)

- (b) An aqueous solution **T** contains **three** metal ions. The following experiments were carried out to identify these metal ions.

Experiment	Observation
1. T was acidified with dilute HCl, and H ₂ S was bubbled through the clear solution obtained.	A black precipitate Q ₁ was formed.
2. Q ₁ was removed by filtration. The filtrate was boiled till all the H ₂ S was removed. The solution was cooled, and NH ₄ Cl and NH ₄ OH were added. H ₂ S was bubbled through the solution.	A clear solution was obtained. A black precipitate Q ₂ was formed.
3. Q ₂ was removed by filtration. The filtrate was boiled till all the H ₂ S was removed, and a solution of (NH ₄) ₂ CO ₃ was added.	A white precipitate Q ₃ was formed.

Experiments for precipitates Q₁, Q₂ and Q₃.

Experiment	Observation
1. Q ₁ was dissolved in hot dilute HNO ₃ . After cooling, the solution was neutralized and KI was added.	A precipitate and a brown solution were formed.
2. Q ₂ was dissolved in warm dilute HCl. The solution was cooled, and dilute NH ₄ OH was added. More dilute NH ₄ OH was added to this mixture.	A green precipitate was formed. The green precipitate dissolved giving a deep blue solution.
3. Q ₃ was dissolved in conc. HCl and the solution was subjected to the flame test.	A green flame was obtained.

(i) Identify the **three** metal ions in solution **T**. (**Reasons are not required.**)

(ii) Write the chemical formulae of the precipitates **Q**₁, **Q**₂, and **Q**₃.

(5.0 marks)

- (c) The following procedure was used to determine the concentration of Al³⁺ ions in solution **U**.

Excess 8-hydroxyquinoline (commonly known as oxine, , C₉H₇ON) was added to 25.0 cm³ of solution

U at pH = 5 to precipitate Al³⁺ ions as aluminium oxinate, Al(C₉H₆ON)₃. The precipitate was filtered, washed with distilled water and dissolved in warm dilute HCl containing excess KBr. Thereafter, 25.0 cm³ of 0.025 mol dm⁻³ KBrO₃ was added to this solution. The reactions taking place in the above procedure are as follows:

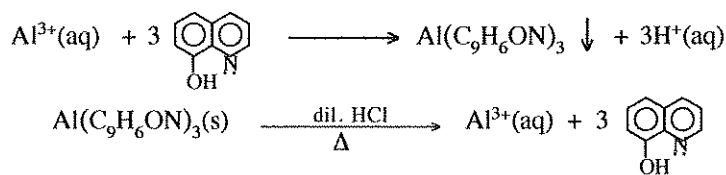

KBrO₃ is a primary standard for the generation of Br₂ in acidic medium.

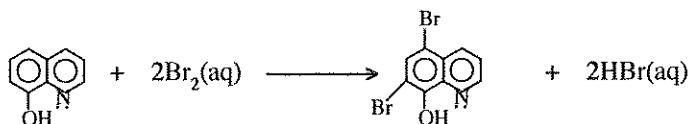
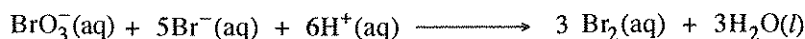

The excess Br₂ is reacted with KI to give I₃⁻. Then I₃⁻ was titrated with 0.05 mol dm⁻³ Na₂S₂O₃ using starch as the indicator. The volume of Na₂S₂O₃ required to reach the end point was 15.00 cm³.

Calculate the concentration of Al³⁺ in solution **U** in mg dm⁻³. (Al = 27)

(5.0 marks)

9. (a) A flow chart drawn by a final year university student to establish a chemical industry in the future in Sri Lanka is given below.

The following symbols are used to represent natural raw materials, manufacturing processes and products.

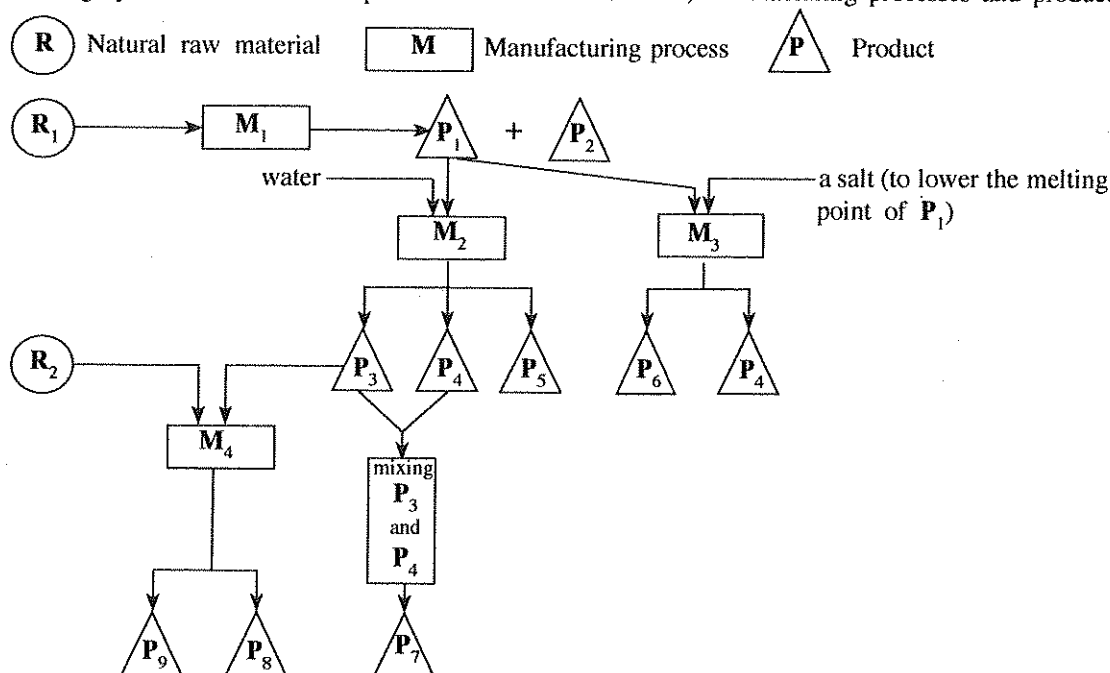

P_2 is used to produce a halogen that exists as a liquid at room temperature.

P_7 is used as a bleaching agent/strong oxidizing agent.

P_8 is used daily to maintain good hygiene.

- (i) Identify the **two** natural raw materials R_1 and R_2 .
- (ii) Identify the **four** manufacturing processes M_1 , M_2 , M_3 and M_4 [e.g. manufacture of ammonia or Haber process]
- (iii) Identify the products P_1 to P_9 .
- (iv) Briefly describe the steps involved in processes M_1 and M_3 . (diagrams of equipment **not** required.)
- (v) Draw and label the equipment used in the process M_2 .
- (vi) Identify the salt used in the process M_3 .
- (vii) Give **one** use for each of P_5 , P_6 and P_9 .

(7.5 marks)

- (b) Answer these questions using the list given below.

CO_2 , CH_4 , volatile hydrocarbons, NO, NO_2 , N_2O , NO_3^- , SO_2 , H_2S , CFC, $CaCO_3$, liquid petroleum and coal

- (i) Identify **two** gaseous species that are responsible for acid rain and briefly explain, with the aid of balanced chemical equations, how these species cause acid rain.
- (ii) Acid rain has harmful effects on the environment. Briefly discuss this statement
- (iii) Identify **three** species that are emitted to the environment due to the burning of fossil fuel, along with one adverse environmental issue for each.
- (iv) "The existence of trace amounts of industrial synthetic species in the atmosphere can cause adverse environmental issues." Explain this statement using CFC as an example.
- (v) Identify **five** greenhouse gases and state a human activity by which each of these gases enters the atmosphere.
- (vi) Briefly explain using balanced chemical equations, how a natural substance (select from the list) can be used to remove acidic gases emitted during the burning of fossil fuel.

(7.5 marks)

10. (a) **X**, **Y** and **Z** are coordination compounds. They have an octahedral geometry. The atomic composition of the species in the coordination sphere (i.e. metal ion and the ligands coordinated to it) in **X**, **Y** and **Z** are $\text{FeH}_{10}\text{CNO}_5\text{S}$, $\text{FeH}_8\text{C}_2\text{N}_2\text{O}_4\text{S}_2$ and $\text{FeH}_6\text{C}_3\text{N}_3\text{O}_3\text{S}_3$ respectively. The oxidation state of the metal ion in all three compounds is the same. In each compound, **two types** of ligands are coordinated to the metal ion. If these compounds contain **non-coordinated** anions, they are of the same type.

An aqueous solution **S** contains **X**, **Y** and **Z** in the molar ratio 1:1:1. The concentration of **each** compound in solution **S** is 0.10 mol dm^{-3} . When excess AgNO_3 solution was added to 100.0 cm^3 of **S**, a yellow precipitate was formed. The precipitate was washed with water and oven dried to a constant mass. The mass of the precipitate was 7.05 g. This precipitate does not dissolve in conc. NH_4OH .

(Relative molecular mass of the chemical compound in the yellow precipitate = 235)

- Identify the ligands coordinated to the metal ions in **X**, **Y** and **Z**.
- Write the chemical formula of the yellow precipitate.
- Giving reasons, determine the structures of **X**, **Y** and **Z**.
- Given below is the structure of ethylenediamine (en)

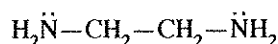

Ethylenediamine coordinates to the metal ion M^{3+} through the two nitrogen atoms, to form the complex ion **Q** (i.e. metal ion and ligands coordinated to it). **Q** has an octahedral geometry.

Write the structural formula of **Q** and draw its structure.

Note: Consider that only ethylenediamine is coordinated to the metal ion. Use the abbreviation 'en' to denote ethylenediamine in your structural formula.

(7.5 marks)

- (b) You are provided with the following.

- 1.0 mol dm^{-3} aqueous solutions of $\text{Al}(\text{NO}_3)_3$, $\text{Cu}(\text{NO}_3)_2$ and $\text{Fe}(\text{NO}_3)_2$
- Al, Cu and Fe metal rods
- Chemicals required to use in salt bridges
- Conducting wires and beakers

In addition to the above, the following data is also provided.

$$E_{\text{Fe}^{2+}/\text{Fe}}^{\circ} = -0.44 \text{ V}, \quad E_{\text{Al}^{3+}/\text{Al}}^{\circ} = -1.66 \text{ V}, \quad E_{\text{Cu}^{2+}/\text{Cu}}^{\circ} = +0.34 \text{ V}$$

- Diagram the **three** electrochemical cells that can be constructed using the above materials. Indicate the anode and cathode along with their signs in each cell.
- For each electrochemical cell drawn in part (i) above
 - give the cell notation.
 - determine E_{cell}° .
 - give balanced chemical equations with physical states for the electrode reactions.
- Giving reasons, explain which of the following compounds is/are appropriate to use in salt bridges.
NaOH, NaNO_3 , acetic acid
- Consider the electrochemical cell which shows the highest E_{cell}° initially. Assume that this electrochemical cell has been constructed using equal volumes of the relevant solutions in each compartment and their volumes do not change during the experiment.

The two electrodes of this cell were connected using a conducting wire and after some time, the concentration of metal ions in the anode compartment was found to be C mol dm^{-3} . Express the concentration of metal ions in the cathode compartment in terms of **C**.

(7.5 marks)

The Periodic Table

1	1 H																2 He	
2	3 Li	4 Be										5 B	6 C	7 N	8 O	9 F	10 Ne	
3	11 Na	12 Mg										13 Al	14 Si	15 P	16 S	17 Cl	18 Ar	
4	19 K	20 Ca	21 Sc	22 Ti	23 V	24 Cr	25 Mn	26 Fe	27 Co	28 Ni	29 Cu	30 Zn	31 Ga	32 Ge	33 As	34 Se	35 Br	36 Kr
5	37 Rb	38 Sr	39 Y	40 Zr	41 Nb	42 Mo	43 Tc	44 Ru	45 Rh	46 Pd	47 Ag	48 Cd	49 In	50 Sn	51 Sb	52 Te	53 I	54 Xe
6	55 Cs	56 Ba	La- Lu	72 Hf	73 Ta	74 W	75 Re	76 Os	77 Ir	78 Pt	79 Au	80 Hg	81 Tl	82 Pb	83 Bi	84 Po	85 At	86 Rn
7	87 Fr	88 Ra	Ac- Lr	104 Rf	105 Db	106 Sg	107 Bh	108 Hs	109 Mt	110 Uun	111 Uuu	112 Uub	113 Uut	...				

57 La	58 Ce	59 Pr	60 Nd	61 Pm	62 Sm	63 Eu	64 Gd	65 Tb	66 Dy	67 Ho	68 Er	69 Tm	70 Yb	71 Lu
89 Ac	90 Th	91 Pa	92 U	93 Np	94 Pu	95 Am	96 Cm	97 Bk	98 Cf	99 Es	100 Fm	101 Md	102 No	103 Lr