

G.C.E.(A.L.) Examination - 2016

Marking Scheme

02 - Chemistry

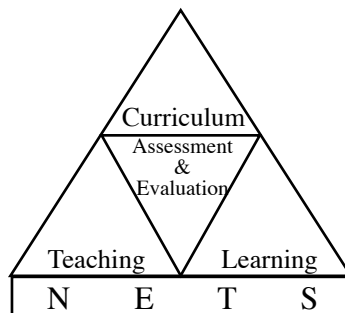

**Research and Development Branch
National Evaluation and Testing Service
Department of Examinations**

PAPERMASTER.LK

2.1.3 Expected answers and the marking scheme for Paper I

Question No.	Answer	Question No.	Answer
01.	4	26.	2
02.	1	27.	1
03.	5	28.	4
04.	4	29.	2
05.	3	30.	3
06.	3	31.	2
07.	4	32.	4
08.	5	33.	1 and 5
09.	5	34.	5
10.	1	35.	3
11.	2	36.	1
12.	4	37.	5
13.	2	38.	4
14.	5	39.	1
15.	2	40.	1
16.	All	41.	2
17.	3	42.	4
18.	2	43.	5
19.	1	44.	3
20.	3	45.	1, 2 and 4
21.	3	46.	5
22.	3	47.	4
23.	1	48.	4
24.	5	49.	5
25.	5	50.	2 and 4

Each correct answer carries 02 marks, amounting the total to 100.

PAPERMASTER.LK

2.2.3 Expected answers, marking scheme and observations and conclusions related to paper II

★ The observations related to the answers for Paper II have been presented by the graphs 2, 3, 4.1, 4.2 and 4.3.

PART A – STRUCTURED ESSAY

Answer **all four** questions on this paper itself. (Each question carries **10** marks.)

Question 1

1. (a) You are provided with the following list of some *p*-block elements in the Periodic Table.

B	C	N	O	F	Ne
Al	Si	P	S	Cl	Ar

From the list,

- | | |
|--|------------------------|
| (i) identify the non-metallic element that forms a homoatomic covalent lattice of high hardness. | C |
| (ii) identify the element that exhibits the widest range of oxidation states. | N/S/P/Cl/C |
| (iii) identify the element that has the highest first ionization energy. | Ne |
| (iv) identify the element that exhibits amphoteric properties. | Al |
| (v) identify the element that has two gaseous allotropes. | O |
| (vi) identify the element that is considered to be the strongest oxidizing agent. | F |
- (04 × 6 = 24 marks)**

Note : If more than one answer is given for a question, award zero marks for that question.

1(a) : 24 marks

(b) The following parts (i) to (v) are based on the molecule CN₄. It has the following skeleton.



(i) Assuming that N—N bond lengths are approximately equal, draw the **most acceptable** Lewis structure for this molecule.

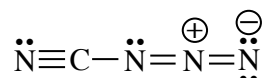

(10 marks)

(ii) Draw **three** resonance structures for this molecule (excluding the structure drawn in part (i) above).

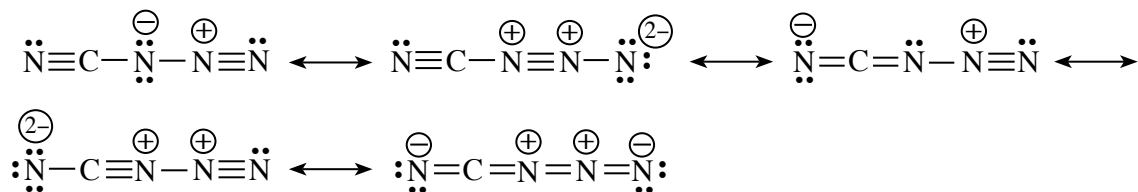

Note : Consider first three responses.

(05 × 3 = 15 marks)

- (iii) Based on the Lewis structure drawn in (i) above, state the following regarding the C and N atoms given in the table below.

- I. VSEPR pairs around the atom. II. electron pair geometry around the atom.
 III. shape around the atom. IV. hybridization of the atom.

The nitrogen atoms of CN_4 are numbered as follows:

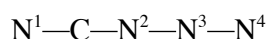

		C	N^2	N^3
I.	VSEPR pairs	2	3	2
II.	Electron pair geometry	Linear	trigonal planar	Linear
III.	Shape	Linear	Angular / V	Linear
IV.	Hybridization	sp	sp^2	sp

(01 × 12 = 12 marks)

- (iv) In the Lewis structure drawn in part (i) above, indicate whether N^2 or N^3 has the **higher** electronegativity. Give reasons for your choice. [Numbering of atoms is as in part (iii).]

$\text{N}^3 > \text{N}^2$ **or** N^3 has higher electronegativity than N^2 (05)

$\text{N}^3 - sp$ and carries a positive charge **or** Oxidation state is +1 (01 + 01)

$\text{N}^2 - sp^2$ and carries zero charge **or** Oxidation state is -1 (01 + 01)

Higher the positive charge/higher the electronegativity/Higher the positive oxidation state (01)

Higher the s -character, higher the electronegativity (01)

- (v) Identify the atomic/hybrid orbitals involved in the formation of the following σ bonds in the Lewis structure drawn in part (i) above. [Numbering of atoms is as in part (iii).]

I. N^1-C $\text{N}^1 \dots sp$ **or** $2p$, $\text{C} \dots sp$

II. $\text{C}-\text{N}^2$ $\text{C} \dots sp$, $\text{N}^2 \dots sp^2$

III. N^2-N^3 $\text{N}^2 \dots sp^2$, $\text{N}^3 \dots sp$

IV. N^3-N^4 $\text{N}^3 \dots sp$, $\text{N}^4 \dots sp^2$ **or** $2p$

(01 × 8 = 08 marks)

Note : Even if the Lewis structure drawn in (b)(i) is wrong, award marks for pair geometry in central atom/around the atom are given.

1(b) : 56 marks

- (c) State whether the following statements are **true** or **false**. (Reasons are **not** required.)

(i) SF_6 and OF_6 are both stable molecules. False

(ii) Although the electron pair geometry of SiCl_4 , NCl_3 and SCl_2 is tetrahedral, their bond angles are different. True

(iii) The boiling point of Kr is greater than that of Xe. False

(iv) The solubility of group II sulphates decreases down the group primarily due to decrease in hydration enthalpy of the cations. True

(05 × 4 = 20 marks)

1(c) : 20 marks

Total for 1 : 100 marks

Question 2

2. (a) **X** and **Y** are *s*-block elements of the Periodic Table. They react with water to form hydroxides. The hydroxide of **X** is more basic than that of **Y**. The hydroxide of **X** is used in the manufacture of baby soap. The hydroxide of **Y** is commonly used to identify the gas **Z** that is one of the main gases responsible for global warming.

(i) Identify **X** and **Y**.

K <u>or</u> potassium

Ca <u>or</u> calcium

(03 + 03)

(ii) Write the electronic configurations of **X** and **Y**.

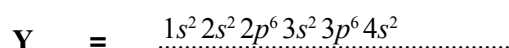
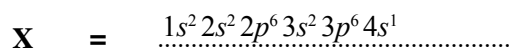

(03 + 03)

(iii) Write the colour of the flame given by salts of **X** and **Y** in the flame test.

X : lilac/violet/reddish-violet.....

Y : brick red/yellow-red/orange red.....

Note : Marks could be awarded for 'orange' colour

(03 + 03)

(iv) Indicate the relative magnitudes of the following in respect of **X** and **Y**.

I. Atomic size

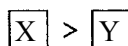

II. Density

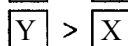

III. Melting point

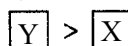

IV. First ionization energy

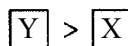

(03 × 4)

Note : If one answer in (a)(i) is correct, award marks for the respective correct answers of (a)(ii) and (a)(iii). Award marks for (a)(iv) only if both **X** and **Y** are correctly identified.

If answer is given as **X** = KOH, **Y** = Ca(OH)₂ do not award marks for (a)(i) and (a)(iv). However, award marks for correct answers of (a)(ii) and (a)(iii).

(v) Identify **Z**.

.....CO₂.....

(03)

(vi) Using balanced chemical equations **only**, indicate how the hydroxide of **Y** could be used to identify **Z**.

Note: Indicate precipitates, if any, using “↓” and colours of precipitates/solutions used in the identification.

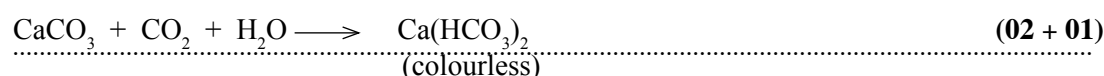
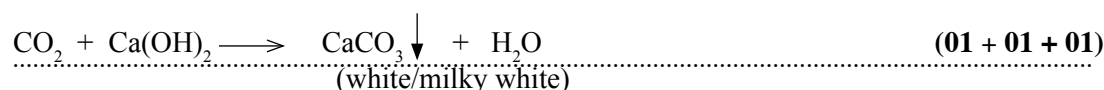

Note : If **Y** has been identified correctly, **Y** could be used instead of Ca.

(vii) A natural source of **Y** in which it is present as a carbonate is used as a raw material in the manufacture of a disinfectant.

I. Name the natural source. limestone/marble/oyster shells (03)

II. Identify the disinfectant. $\text{Ca(OCl)}_2 \cdot \text{Ca(OH)}_2 \cdot \text{CaCl}_2 \cdot 2\text{H}_2\text{O(s)}$ / Ca(OCl)_2 /
Bleaching powder (03)

III. Write the steps in the manufacturing process of the disinfectant, using balanced chemical equations **only**.

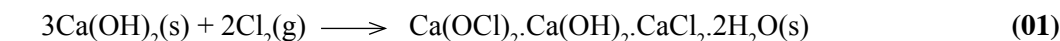
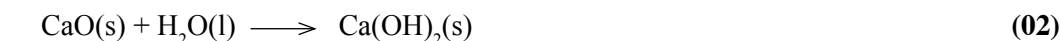

Note : Physical states are not required.

2(a) : 50 marks

(b) (i) Complete the reactions given below by selecting the appropriate solution from the given list and writing in the box.

List of solutions (not in order)

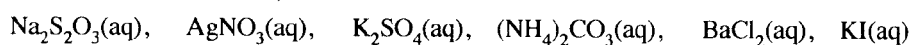

Note: A solution should be used **only once**.

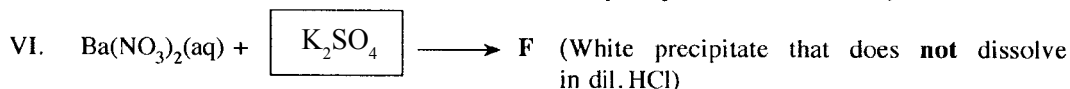
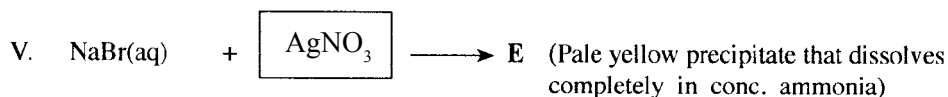
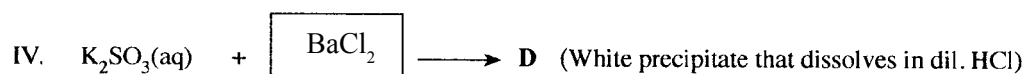
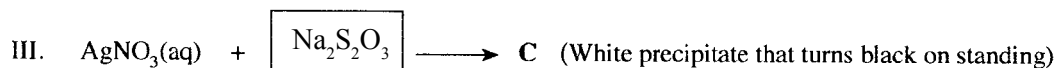
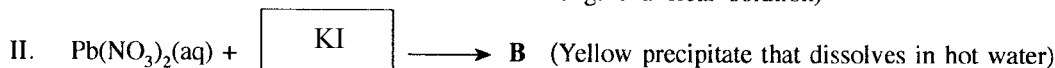
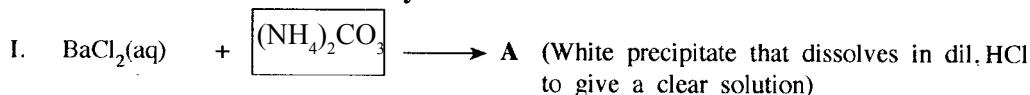

(04 × 6 = 24 marks)

(ii) Write the chemical formulae of the precipitates **A** to **F**.

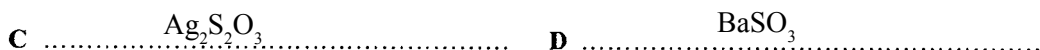
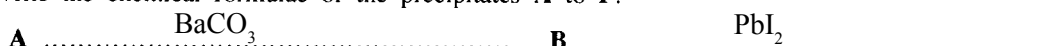

(03 × 6 = 18 marks)

(iii) Write balanced chemical equations for the dissolution of precipitates **A**, **D** and **E** in (b)(i) above.

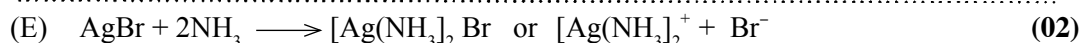
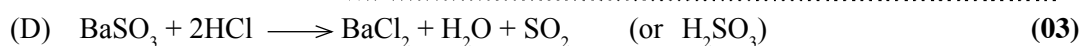

Note : Mark (b)(iii) independently.

2(b) : 50 marks

Total for 2 : 100 marks

PAPERMASTER.LK

Question 3

3. (a) When 0.010 moles of gas A is placed in a 1.0 dm³ evacuated closed rigid container in the presence of a small amount of a solid catalyst, at 227 °C, it decomposes as shown below.



The concentration of A(g) was measured over time. The results are shown in the following graph.

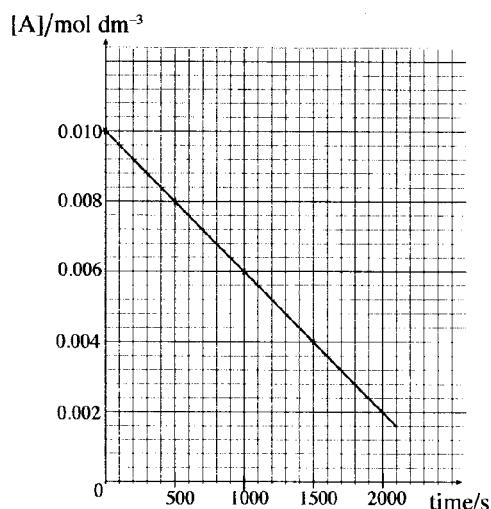

- (i) Taking the order and the rate constant of the reaction as **a** and **k**, respectively, write the rate expression for the above reaction.

Rate = $k[A]^a$ **or** (10)

$\left[-\frac{\Delta[A]}{\Delta t} = k[A]^a \text{ or } -\frac{d[A]}{dt} = k[A]^a \right]$ if (-) sign is not included do not award marks

- (ii) Giving reasons, determine the value of **a**.

Rate = $k[A]^0$ **or** order = $a = 0$ (10)

Rate = constant (gradient is constant) **or** Rate is independent of concentration (05)

- (iii) Calculate the rate constant, **k** at 227 °C.

Rate constant, $k = |\text{Rate}|$ (05)

$k = \left| \frac{(0.002 - 0.01) \text{ mol dm}^{-3}}{2000 \text{ s}} \right|$ **or** any two points (04 + 01)

$k = 4.0 \times 10^{-6} \text{ mol dm}^{-3}$ (04 + 01)

- (iv) Calculate the pressure in the container when half the initial amount of A(g) has decomposed. Assume that the volume of the catalyst can be neglected.

Volume of the container = 1.0 dm³



After 50% completion

$0.01(1-x) \quad 0.01x \quad 0.01x$ [concentrations in mol dm⁻³]

Amount of gas $t = 0$ = 0.01 mol

Amount of gas after 50% is decomposed = (0.005 + 0.005 + 0.005) mol

= 0.015 mol (05)

Assuming ideal gas behaviour, apply $PV = nRT$

$$\begin{aligned} \text{Pressure} &= \frac{0.015 \text{ mol } 8.314 \text{ JK}^{-1} \text{ mol}^{-1} 500 \text{ K}}{10^{-3} \text{ m}^3} && \text{(08 + 02)} \\ &= 6.23 \times 10^4 \text{ Pa} && \text{(04 + 01)} \end{aligned}$$

3(a) : 60 marks

- (b) In the presence of a solid catalyst, the gas **X** decomposes according to the following chemical equation.

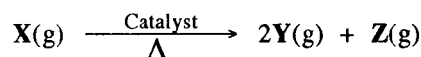

1.0 mole of gas **X** was introduced to an evacuated container. The initial volume of the gas was measured to be V_0 . The reaction was initiated by introducing a small amount of catalyst (volume is negligible). The rate constant of the catalysed reaction is k_1 and order of the reaction with respect to **X** is **b**. The initial rate of the reaction was measured as R_0 . The pressure of the system was maintained at a constant value by allowing the container to expand. The temperature of the system was also maintained at a constant value.

- (i) Write an expression for R_0 using the terms **b**, k_1 and V_0 .

Initial rate, $R_0 = k_1 [\text{X}]^b$

.....

$$R_0 = k_1 \left(\frac{1.0 \text{ mol}}{V_0} \right)^b \text{ --- (1)} \quad \text{(10)}$$

.....

(Units are not required)

- (ii) It was observed that the rate of the reaction was $0.25R_0$ and the volume of the container was doubled when 50% of **X(g)** was consumed. Calculate the order **b** of the reaction.

After 50% decomposition,

.....

$$[\text{X}] = \frac{0.5 \text{ mol}}{2V_0} \quad \text{(05)}$$

.....

At this stage, Rate = $0.25R_0$

.....

$$0.25R_0 = k_1 \left(\frac{0.5 \text{ mol}}{2V_0} \right)^b \text{ --- (2)} \quad \text{(10)}$$

.....

From (2)/(1),

.....

$$\frac{0.25 R_0}{R_0} = \frac{k_1 \left(\frac{0.5 \text{ mol}}{2V_0} \right)^b}{k_1 \left(\frac{1.0 \text{ mol}}{V_0} \right)^b} \quad \text{(10)}$$

.....

$$0.25 = 0.25^b$$

$$b = 1 \quad \text{(05)}$$

(Units are not required)

3(b) : 40 marks

Total for 3 : 100 marks

Question 4

4. (a) (i) **A, B, C** and **D** are structural isomers with the molecular formula $C_4H_{10}O$. All four isomers reacted with metallic sodium to evolve H_2 gas. Of the four isomers, only **A** exhibited optical isomerism. When **B, C** and **D** were added separately to conc. HCl , containing $ZnCl_2$, the mixture containing **B** became turbid very rapidly. The development of turbidity with **C** and **D** was very slow. When **C** and **D** were heated with conc. H_2SO_4 , **E** and **F** were respectively obtained. **E** and **F** are structural isomers with the molecular formula C_4H_8 . Neither **E** nor **F** exhibited geometric isomerism. When **E** and **F** were treated with HBr , **G** and **H** were respectively obtained. Only **G** exhibited optical isomerism. Draw the structures of **A, B, C, D, E, F, G** and **H** in the boxes given below. (It is **not necessary** to draw stereoisomeric forms.)

$CH_3CH_2\underset{\substack{ \\ OH}}{CH}-CH_3$	$CH_3-\overset{\substack{OH \\ }}{C}-\underset{\substack{ \\ OH}}{CH_3}$	$CH_3CH_2CH_2CH_2OH$
A	B	C
$CH_3-\overset{\substack{CH_3 \\ }}{C}-\underset{\substack{ \\ H}}{CH_2}OH$	$CH_3CH_2CH=CH_2$	$CH_3-\overset{\substack{CH_3 \\ }}{C}=CH_2$
D	E	F
$CH_3CH_2\underset{\substack{ \\ Br}}{CH}-CH_3$	$CH_3-\overset{\substack{CH_3 \\ }}{C}-\underset{\substack{ \\ Br}}{CH_3}$	Note : If A is incorrect, no marks for I. If C is incorrect, no marks for J.
G	H	

(05 × 8 = 40 marks)

- (ii) When **A** and **C** were reacted with PCC, **I** and **J** were respectively obtained. Draw the structures of **I** and **J** in the boxes given below. (PCC = Pyridinium chlorochromate)

$C_2H_5-\overset{\substack{O \\ }}{C}-CH_3$	$CH_3CH_2CH_2-\overset{\substack{O \\ }}{C}-H$
I	J

(05 × 2 = 10 marks)

4(a) : 50 marks

- (b) Draw the structure of the **major** organic products **K, L, M, N, O, P, Q, R, S** and **T** of the following reactions in the relevant boxes given on page 8.

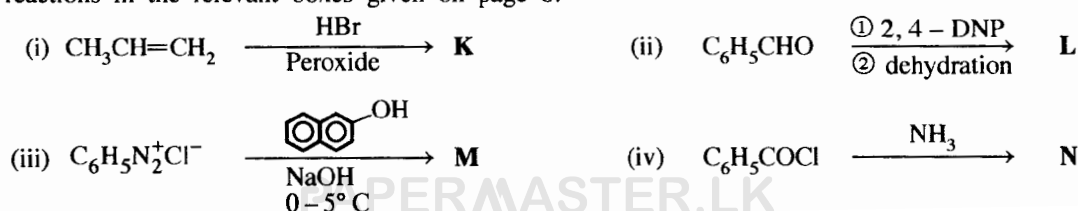

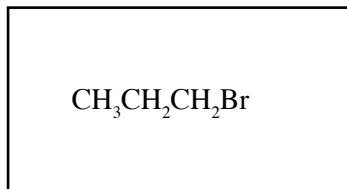
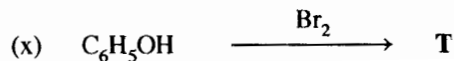
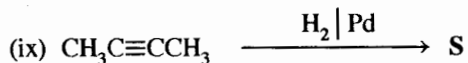
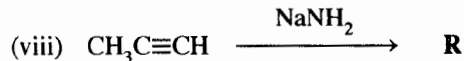
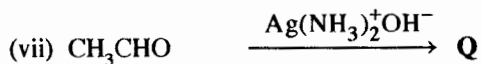
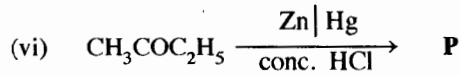
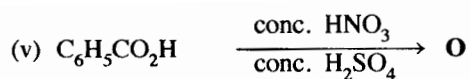

K

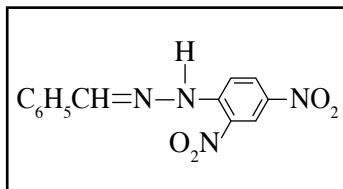

L

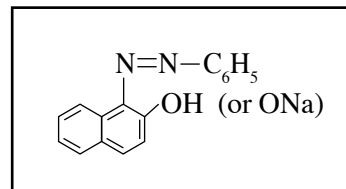

M

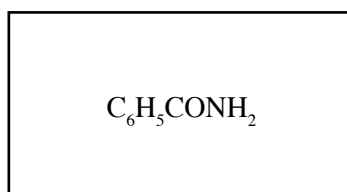

N

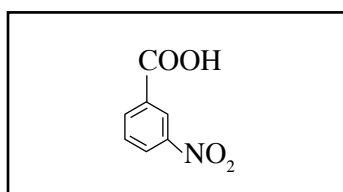

O

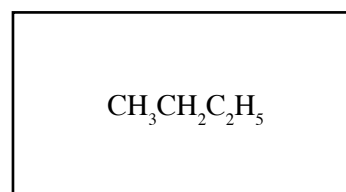

P

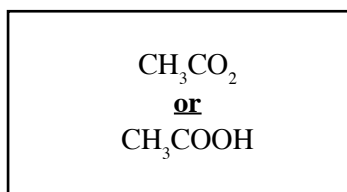

Q

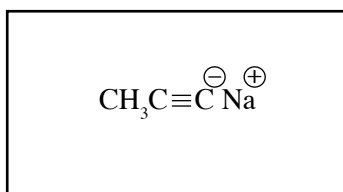

R

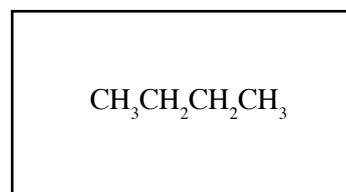

S

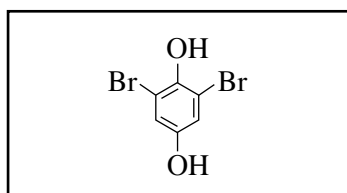

T

Note : **Q** : Disregard cation

R : Do not award marks for the following structures

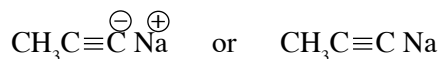

(03 × 10 = 30 marks)

4(b) : 30 marks

(c) Write the mechanism for the reaction between $C_2H_5CH=CHC_2H_5$ and $Br_2(CCl_4)$.

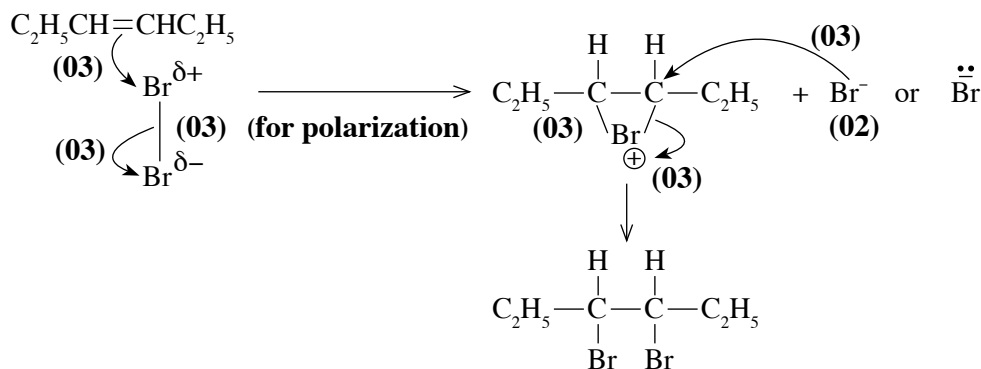

Nate : If cyclic intermediate is not drawn, do not award 06 marks

4(c) : 20 marks

Total for 4 : 100 marks

PAPERMASTER.LK

Question 5

5. (a) The procedure given below was followed to determine the partition coefficient, K_D of butanedioic acid (BDA, $\text{HOOCCH}_2\text{CH}_2\text{COOH}$) between ether and water at 25 °C.

Initially, 20 g of solid BDA was shaken well with a mixture of approximate volumes of 100 cm³ of ether and 100 cm³ of water in a reagent bottle and the layers were allowed to separate. At this stage, some undissolved BDA was seen remaining at the bottom of the reagent bottle. Thereafter, a 50.00 cm³ volume of ether layer and a 25.00 cm³ volume of water layer were titrated with 0.05 mol dm⁻³ NaOH solution. The volumes taken from the ether and water layers required 4.80 cm³ and 16.00 cm³ of the NaOH solution respectively.

- Calculate the partition coefficient, K_D for the distribution of butanedioic acid between ether and water at 25 °C.
- Calculate the solubility of butanedioic acid in ether, given that the solubility of this acid in water is 8.0 g dm⁻³.

- (b) Consider the following reactions. Thermodynamic data supplied are **not** for the standard state.

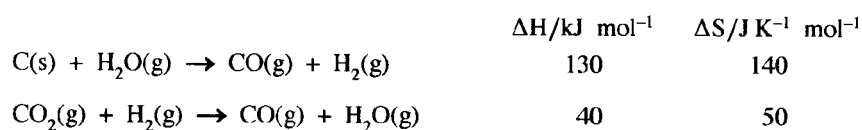

- Calculate ΔH and ΔS for the reaction $2\text{CO(g)} \rightarrow \text{C(s)} + \text{CO}_2\text{(g)}$. State giving reasons whether the sign of ΔS agrees with the reaction taking place.
 - By means of a suitable calculation, predict whether the reaction given in part (i) above is spontaneous at 27 °C.
- (c) An excess amount of C(s) and 0.15 mol of CO₂(g) were placed in a closed rigid 2.0 dm³ container and the system was allowed to reach equilibrium at a temperature of 689 °C. Once the equilibrium was achieved, the pressure in the container was found to be 8.0×10^5 Pa. (Take $RT = 8000 \text{ J mol}^{-1}$ at 689 °C)
- Write an expression for the equilibrium constant, K_p for the reaction $\text{C(s)} + \text{CO}_2\text{(g)} \rightleftharpoons 2\text{CO(g)}$.
 - Calculate K_p and K_c at 689 °C.
 - In another experiment, the container described above contains an excess of C(s) together with CO(g) and CO₂(g) at 689 °C. The initial partial pressure of each gas is 2.0×10^5 Pa. Explain, with the aid of a calculation, the change in partial pressure of CO₂(g) when the system reaches equilibrium.

5. (a) (i) $\frac{n_{\text{butanedioic acid}}}{n_{\text{NaOH}}} = \frac{1}{2}$ **or** for the identification of stoichiometry (05)

Butanedioic acid = BDA

Ether layer

$$C_{\text{BDA}_{\text{ether}}} = \frac{1}{2} \times 0.05 \text{ mol dm}^{-3} \times 4.8 \text{ cm}^3 / 50.00 \text{ cm}^3 \quad (03)$$

$$= 2.4 \times 10^{-3} \text{ mol dm}^{-3} \quad (04 + 01)$$

Aqueous layer

$$C_{\text{BDA}_{\text{aq}}} = \frac{1}{2} \times 0.05 \text{ mol dm}^{-3} \times 16.0 \text{ cm}^3 / 25.00 \text{ cm}^3 \quad (02)$$

$$= 1.6 \times 10^{-2} \text{ mol dm}^{-3} \quad (04 + 01)$$

$$K_D = \frac{[\text{BDA}]_{\text{ether}}}{[\text{BDA}]_{\text{aqueous}}} \quad (05)$$

$$= \frac{2.4 \times 10^{-3} \text{ mol dm}^{-3}}{1.6 \times 10^{-2} \text{ mol dm}^{-3}} = 0.15 \text{ or } 3/20 \quad (04 + 01)$$

or $K_D = \frac{[\text{BDA}]_{\text{aqueous}}}{[\text{BDA}]_{\text{ether}}}$

$$= \frac{1.6 \times 10^{-2} \text{ mol dm}^{-3}}{2.4 \times 10^{-3} \text{ mol dm}^{-3}} = 6.67 \text{ or } 20/3$$

Note : Steps can be combined, award marks accordingly.

(ii) Solubility

$$[BDA]_{\text{ether}} = K_D [BDA]_{\text{Water}} \quad (03)$$

$$= 2.4 \times 10^{-3} \text{ mol dm}^{-3} \quad (04 + 01)$$

Consider a mixture having 1.0 dm^3 of ether layer and 1.0 dm^3 of aqueous layer.

$$\frac{x}{M_{\text{BDA}}} = \frac{0.15(8.0 \text{ g dm}^{-3})}{M_{\text{BDA}}} \quad (05)$$

$$x = 1.2 \text{ g dm}^{-3} \quad (04 + 01)$$

Note : Equation can be accepted without M_{BDA} .

5(a) : 40 marks

(b) (i) Write the two reactions as follows and add.

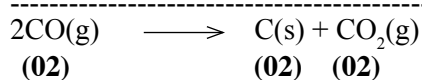
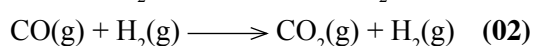
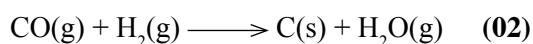

(Overall reaction must be generated by adding the two reactions for awarding marks)

(Physical states are required)

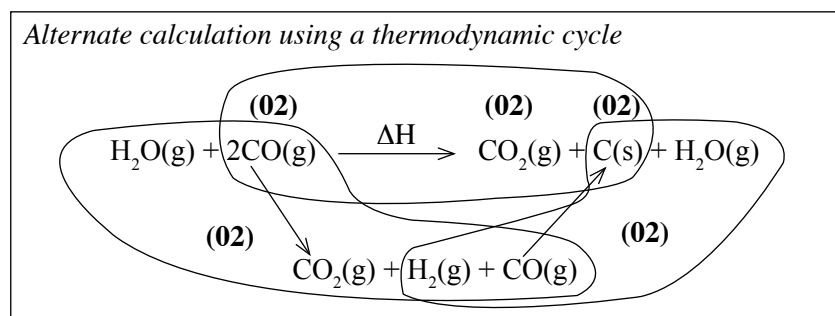

$$\Delta H = -130 \text{ kJ mol}^{-1} - 40 \text{ kJ mol}^{-1} = -170 \text{ kJ mol}^{-1} \quad (04 + 01)$$

$$\Delta S = -140 \text{ J K}^{-1} \text{ mol}^{-1} - 50 \text{ J K}^{-1} \text{ mol}^{-1} = -190 \text{ J K}^{-1} \text{ mol}^{-1} \quad (04 + 01)$$

(If standard states are written, do not award marks)

Sign of ΔS is negative. This agrees with the reduction of entropy, mainly due to the reduction of the number of moles of gases as the forward reaction progresses. (05)

(ii) Find ΔG at 27°C .

$$\Delta G = \Delta H - T\Delta S \quad (02)$$

(If standard states are written, do not award marks)

$$\Delta G = -170 \text{ kJ mol}^{-1} - 300 \text{ K}^{-1} \text{ mol}^{-1} \times (-190 \times 10^{-3} \text{ kJ K}^{-1} \text{ mol}^{-1}) \quad (04 + 01)$$

$$\Delta G = -113 \text{ kJ mol}^{-1} \quad (04 + 01)$$

Forward reaction is spontaneous. (03)

(Calculation must be shown for last 03 marks)

5(b) : 40 marks

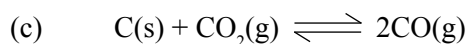

(i) $K_p = \frac{P_{CO}^2}{P_{CO_2}}$ (05)

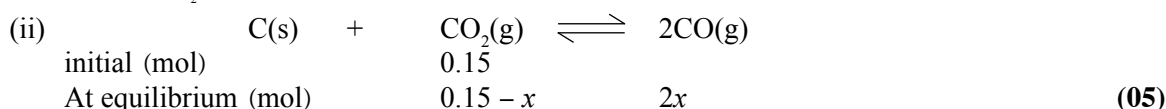

Total number of gas moles = 0.15 - x (04 + 01)

Apply PV = nRT assuming ideal behaviour.

$$0.15 + x = \frac{8.0 \times 10^5 \text{ Pa} \cdot 2.0 \times 10^{-3} \text{ m}^3}{8.0 \times 10^5 \text{ J mol}^{-2}} \quad (04 + 01)$$

$$x = 0.05 \text{ mol} \quad (04 + 01)$$

$n_{CO} = 0.1 \text{ mol}$ $n_{CO_2} = (0.15 - 0.05) \text{ mol} = 0.10 \text{ mol}$

(03) (02)

Therefore,

$P_{CO} = 2 \times 0.05 \times 8.0 \times 10^5 \text{ Pa} / 0.2 = 4.0 \times 10^5 \text{ Pa}$ (04 + 01)

$P_{CO_2} = 0.1 \times 8.0 \times 10^5 \text{ Pa} / 0.2 = 4.0 \times 10^5 \text{ Pa}$ (04 + 01)

$$K_p = \frac{(4.0 \times 10^5 \text{ Pa})^2}{4.0 \times 10^5 \text{ Pa}} \quad (04 + 01)$$

$$= 4.0 \times 10^5 \text{ Pa} \quad (04 + 01)$$

Alternate calculation

$n_{\text{total}} = 0.20 \text{ mol}, \therefore X_{CO} = X_{CO_2} = 1/2$ (05)

$P_{CO} = 8 \times 10^3 \times 1/2 = 4 \times 10^3 \text{ Pa}$ (04 + 01)

$P_{CO_2} = 8 \times 10^3 \times 1/2 = 4 \times 10^3 \text{ Pa}$ (04 + 01)

$K_p = (4 \times 10^3 \text{ Pa})^2 / 4 \times 10^3 \text{ Pa}$ (04 + 01)

$K_p = 4 \times 10^3 \text{ Pa}$ (04 + 01)

$K_c = K_p(RT)^{-\Delta n}$ **or** $K_p = K_c(RT)^{-\Delta n}$ (03)

$\Delta n = 1$ (02)

$K_c = 4.0 \times 10^5 \text{ Pa} \times (8 \times 10^3 \text{ J mol}^{-1})^{-1}$

$K_c = 50 \text{ mol m}^{-3}$ **or** 0.05 mol dm^{-3} (04 + 01)

Alternate calculation

$K_c = [CO]^2 / [CO_2]$ (05)

$= [0.10 / (2 \times 10^{-3})]^2 / [0.10 / (2 \times 10^{-3})]$

$= 50 \text{ mol m}^{-3} (0.05 \text{ mol dm}^{-3})$ (04 + 01)

(iii) Calculate Q using the pressures.

$$Q = \frac{(2.0 \times 10^5 \text{ Pa})^2}{2.0 \times 10^5 \text{ Pa}} = 2.0 \times 10^5 \text{ Pa} \quad (05)$$

Q is smaller than K_p . Therefore, P_{CO_2} decreases and P_{CO} increases until $Q = K_p$. (05)

Alternate calculation

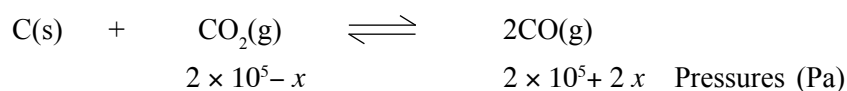

$$K_p = 4.0 \times 10^5 = \frac{(2 \times 10^5 + 2x)^2}{2.0 \times 10^5 - x} \quad (05)$$

Solving the quadratic equation and predicting the P_{CO_2} decreases and P_{CO} increases. (05)

5(c) : 70 marks

PAPERMASTER.LK

Total for 5 : 150 marks

Question 6

6. (a) A 0.10 mol dm^{-3} solution of a weak acid, **HA** was prepared by diluting an appropriate amount of the pure weak acid to 25.00 cm^3 with distilled water in a volumetric flask at $25 \text{ }^\circ\text{C}$. The pH of this solution was 3.0.
- Considering the equation, $\text{HA}(\text{aq}) + \text{H}_2\text{O}(\text{l}) \rightleftharpoons \text{H}_3\text{O}^+(\text{aq}) + \text{A}^-(\text{aq})$, calculate the dissociation constant, K_a of the weak acid.
 - A dilute solution of this weak acid, **HA** was titrated with a strong base, **BOH**. It was found that the pH of the titration mixture after reaching the equivalence point was 9.0. Calculate the concentration of the salt, **AB** in the titration mixture. ($K_w = 1.0 \times 10^{-14} \text{ mol}^2 \text{ dm}^{-6}$ at $25 \text{ }^\circ\text{C}$)
 - The above titration mixture was diluted hundred times by adding distilled water. Calculate the pH of the diluted titration mixture.
- (b) $\text{AgBr}(\text{s})$ is a pale-yellow coloured salt sparingly soluble in water. Its solubility product, K_{sp} is $5.0 \times 10^{-13} \text{ mol}^2 \text{ dm}^{-6}$ at $25 \text{ }^\circ\text{C}$.
- Calculate the concentration of $\text{Ag}^+(\text{aq})$ in a saturated solution of AgBr in equilibrium with solid AgBr at $25 \text{ }^\circ\text{C}$.
 - Solid AgBr together with 100.0 cm^3 of the solution described in part (i) above were placed in a beaker. A volume of 100.0 cm^3 of distilled water was added to the beaker and the mixture was stirred well until the equilibrium is reached. At this stage, some solid AgBr was still left at the bottom of the beaker. What could be the concentration of $\text{Ag}^+(\text{aq})$ in this solution? Explain your answer.
 - Using a suitable calculation, predict the observation expected when 10.0 cm^3 of a $1.5 \times 10^{-4} \text{ mol dm}^{-3}$ AgNO_3 solution and 5.0 cm^3 of a $6.0 \times 10^{-4} \text{ mol dm}^{-3}$ NaBr solution are mixed at $25 \text{ }^\circ\text{C}$.
- (c) (i) The pressure of the vapour phase in equilibrium with an ideal binary solution is P . The liquid phase mole fractions of the two components are X_1 and X_2 , and their respective saturated vapour pressures are P_1^0 and P_2^0 . Show that
- $$X_1 = \frac{P - P_2^0}{P_1^0 - P_2^0}.$$
- The pressure of the vapour phase in equilibrium with a binary solution containing methanol and ethanol is $4.5 \times 10^4 \text{ Pa}$ at $50 \text{ }^\circ\text{C}$. At this temperature the saturated vapour pressures of methanol and ethanol are $5.5 \times 10^4 \text{ Pa}$ and $3.0 \times 10^4 \text{ Pa}$ respectively. Consider that the solutions behave ideally.
 - Calculate the mole fractions of methanol and ethanol in the liquid phase.
 - Calculate the mole fractions of methanol and ethanol in the vapour phase.
 - Based on the above calculations and given information, draw the vapour pressure - composition diagram of the methanol - ethanol mixture at $50 \text{ }^\circ\text{C}$. Consider that the solutions behave ideally.

6. (a) (i) pH = 3.0

$$[\text{H}^+] = 1.0 \times 10^{-3} \text{ mol dm}^{-3} \quad (04 + 01)$$

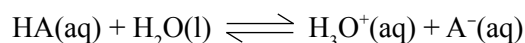

$$K_a = \frac{[\text{H}_3\text{O}^+(\text{aq})][\text{A}^-(\text{aq})]}{[\text{HA}(\text{aq})]} \quad (02)$$

(Physical states are required)

$$= \frac{(1.0 \times 10^{-3} \text{ mol dm}^{-3})^2}{0.10 \text{ mol dm}^{-3}} \quad (02 + 01)$$

$$= 1.0 \times 10^{-5} \text{ mol dm}^{-3} \quad (02 + 01)$$

(ii) pH at the equivalence point is determined by the degree of hydrolysis of the salt.

Consider,



$$\frac{K_a}{K_w} = \frac{[H_3O^+(aq)][A^-(aq)]}{[HA(aq)][OH^-(aq)]}$$

At the equivalence point $[HA(aq)] \approx [OH^-(aq)]$

$$\frac{K_a}{K_w} = \frac{[A^-(aq)]}{[OH^-(aq)]^2}$$

$$[OH^-(aq)] = \left[[A^-(aq)] \frac{K_w}{K_a} \right]^{1/2} \quad (1) \quad (05)$$

At the equivalence point $[A^-(aq)] = [\text{salt}]$

Since pH = 9.0 at the equivalence point, $[OH^-] = 10^{-5} \text{ mol dm}^{-3}$ (02)

$$[\text{salt}] = ([OH^-(aq)])^2 \frac{K_a}{K_w}$$

$$[\text{salt}] = (1.0 \times 10^{-5} \text{ mol dm}^{-3})^2 \frac{1.0 \times 10^{-5} \text{ mol dm}^{-3}}{1.0 \times 10^{-14} \text{ mol}^2 \text{ dm}^{-6}} \quad (04 + 01)$$

$$= 0.1 \text{ mol dm}^{-3} \quad (04 + 01)$$

(iii) When the titration mixture at the equivalence point is 100 times diluted,

(The salt concentration is decreased by 100 times)

Using the equation - (1)

$$[OH^-(aq)]_{\text{new}} = \left[\frac{[A^-(aq)]}{100} \frac{K_w}{K_a} \right]^{1/2} \quad (05)$$

$$[OH^-(aq)]_{\text{new}} = \frac{1}{10} \left[\frac{[A^-(aq)]}{1} \frac{K_w}{K_a} \right]^{1/2}$$

$$[OH^-(aq)]_{\text{new}} = \frac{1}{10} \left[\frac{[0.1 \text{ mol dm}^{-3}]}{1} \frac{1 \times 10^{-5} \text{ mol}^2 \text{ dm}^{-6}}{1 \times 10^{-14} \text{ mol}^2 \text{ dm}^{-6}} \right]^{1/2} \quad (04 + 01)$$

$$[OH^-(aq)] = 1.0 \times 10^{-6} \text{ mol dm}^{-3}$$

$$[H_3O^+(aq)] = 1.0 \times 10^{-8} \text{ mol dm}^{-3}$$

Therefore, pH = 8.0 (05)

Alternate calculation

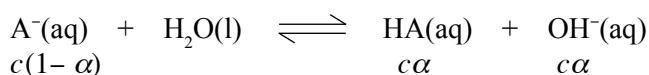

By Ostwalds law,

$$K_b = \alpha^2 c = \frac{\alpha^2 c^2}{c} = \frac{[OH^-]^2}{c}$$

$$[OH^-] = \sqrt{K_b c} = \sqrt{\frac{K_a}{K_w} c} \qquad \qquad \qquad (05)$$

$$[\text{salt}] = [A^-] = c = 0.1 \text{ mol dm}^{-3}/100$$

$$[OH^-] = \sqrt{\frac{1 \times 10^{-14} \text{ mol}^2 \text{ dm}^{-6}}{1 \times 10^{-5} \text{ mol dm}^{-3}} \times \frac{1 \times 10^{-1} \text{ mol dm}^{-3}}{100}} = 1 \times 10^{-6} \text{ mol dm}^{-3} \qquad (04 + 01)$$

$$\text{pOH} = 6.0$$

$$\text{pH} = 8.0 \qquad \qquad \qquad (05)$$

6(a) : 50 marks



$$K_{SP} = [\text{Ag}^+(aq)][\text{Br}^-(aq)] \qquad \qquad \qquad (03)$$

$$[\text{Ag}^+(aq)] = [\text{Br}^-(aq)] = x$$

$$K_{SP} = x^2 \qquad \qquad \qquad (02)$$

$$\text{Therefore, } [\text{Ag}^+(aq)] = (5.0 \times 10^{-13})^{1/2}$$

$$= 7.07 \times 10^{-7} \text{ mol dm}^{-3} \quad \text{or} \quad 7.1 \times 10^{-7} \text{ mol dm}^{-3} \qquad \qquad \qquad (04 + 01)$$

(ii) The solution is a saturated solution of AgBr. (05)

$$\text{Therefore, } [\text{Ag}^+(aq)] \text{ is as same as above, } 7.07 \times 10^{-7} \text{ mol dm}^{-3} \qquad \qquad \qquad (05)$$

(iii) The product of concentrations of Ag^+ and Br^- must be calculated and compared with K_{SP} .

$$\begin{aligned} [\text{Ag}^+(aq)] &= 1.5 \times 10^{-4} \text{ mol dm}^{-3} \times 10.00 \text{ cm}^3 / 15.00 \text{ cm}^3 \\ &= 1.0 \times 10^{-4} \text{ mol dm}^{-3} \qquad \qquad \qquad (04 + 01) \end{aligned}$$

$$\begin{aligned} [\text{Br}^-(aq)] &= 6.0 \times 10^{-4} \text{ mol dm}^{-3} \times 5.00 \text{ cm}^3 / 15.00 \text{ cm}^3 \\ &= 2.0 \times 10^{-4} \text{ mol dm}^{-3} \qquad \qquad \qquad (04 + 01) \end{aligned}$$

$$[\text{Ag}^+(aq)] \times [\text{Br}^-(aq)] = 2.0 \times 10^{-8} \text{ mol}^2 \text{ dm}^{-6} > K_{SP} \qquad \qquad \qquad (10)$$

[or any other correct approach]

Therefore, AgBr will precipitate (slightly yellow oreprecitate will form) (05)

PAPERMASTER.LK

6(b) : 50 marks

(c) (i) Applying Raoult's law to the ideal binary mixture,

$$P_i = x_i P_i^0 \quad (05)$$

$$P = P_1 + P_2 \quad (05)$$

$$P = x_1 P_1^0 + x_2 P_2^0 \quad (05)$$

$$x_2 = 1 - x_1$$

$$P = x_1 P_1^0 + (1 - x_1) P_2^0$$

$$x_1 = \frac{(P - P_2^0)}{(P_1^0 - P_2^0)} \quad (05)$$

(ii) I Mole fractions in the liquid phase,

$$x_{\text{meOH}} = (4.5 - 3.0)10^4 \text{ Pa} / (5.5 - 3.0)10^4 \text{ Pa} = 0.6 \quad (04 + 01)$$

$$x_{\text{etOH}} = 1 - 0.6 = 0.4 \quad (04 + 01)$$

II Mole fractions in the gas phase,

$$x_{\text{methanol_gas}} = 0.6 \times 5.5 \times 10^4 \text{ Pa} / 4.5 \times 10^4 \text{ Pa} = 0.73 \quad (04 + 01)$$

$$x_{\text{ethanol_gas}} = 1.0 - 0.73 = 0.27 \quad (04 + 01)$$

(Answers can be given as fractions)

(iii) Pressure composition diagram (ideal mixture)

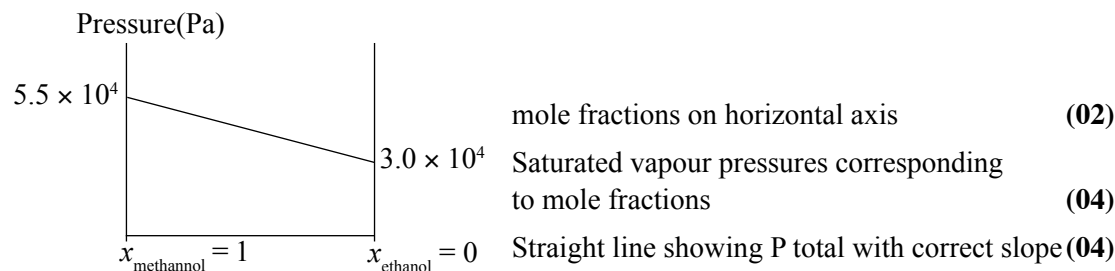

Note : If more than one line is drawn, P total line must be labeled.

6(c) : 50 marks

Total for 6 : 150 marks

Question 7

7. (a) Using **only** the chemicals given in the list, show how you would carry out the following conversion.

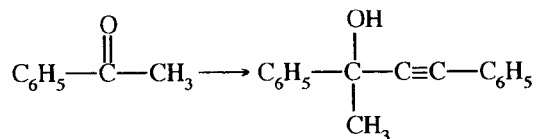

List of chemicals

H_2O , alcoholic KOH , Br_2 , Conc. H_2SO_4 ,
 NaBH_4 , $\text{C}_2\text{H}_5\text{MgBr}$ /dry ether

Your conversion should not exceed 9 steps.

(b) Identify $\text{R}_1 - \text{R}_6$ and $\text{X}_1 - \text{X}_5$ in order to complete the following reaction scheme.

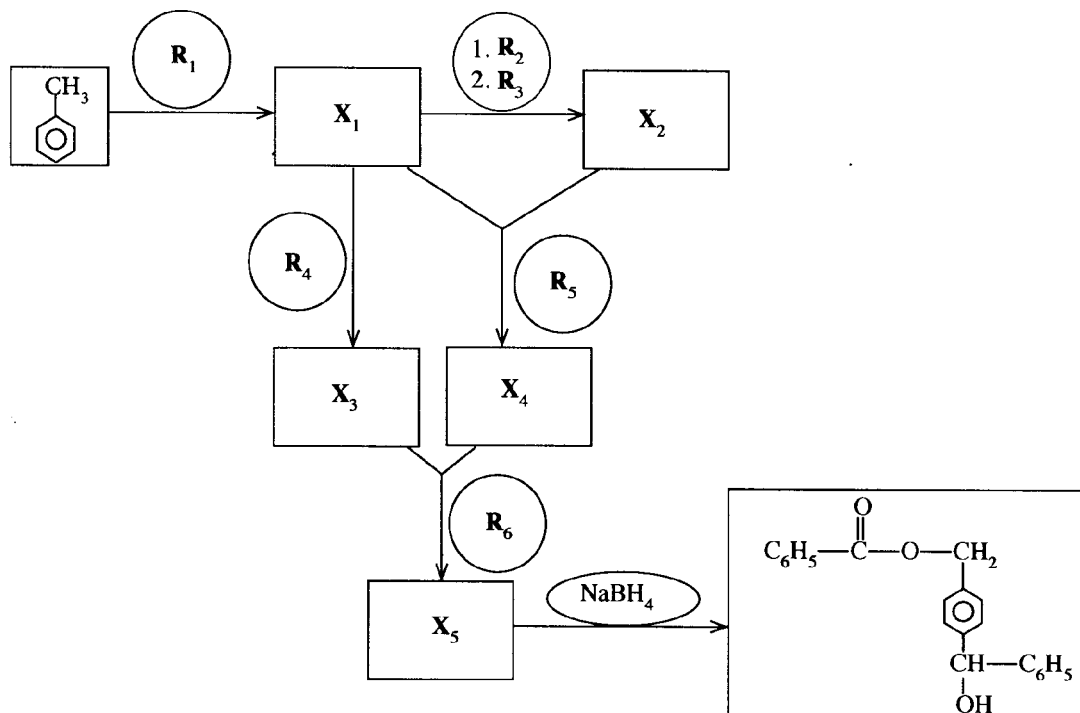

(c) (i) Give the mechanism for the following reaction.

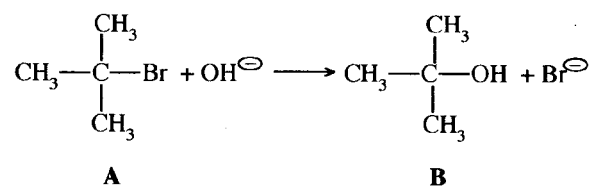

(ii) The reaction of **A** with NaOH , gives in addition to **B** another product **C**. Give the structure of **C**.

7. (a)

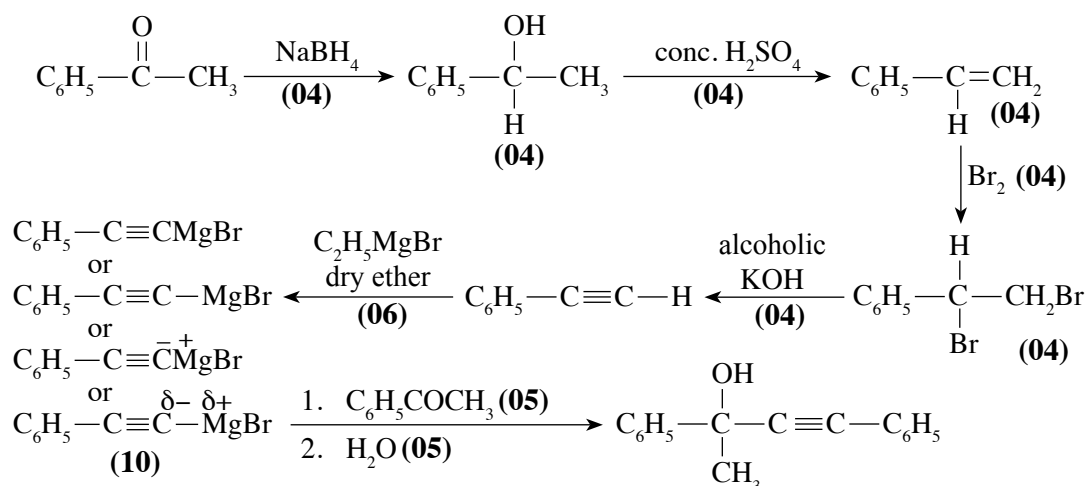

Note : Disregard reaction medium of NaBH₄.

Alternate step

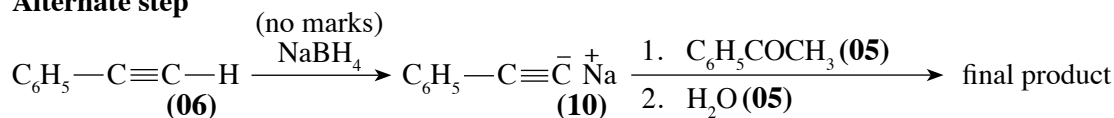

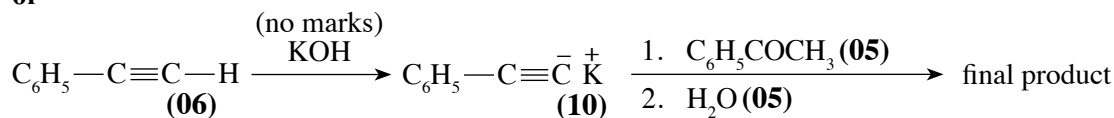

or

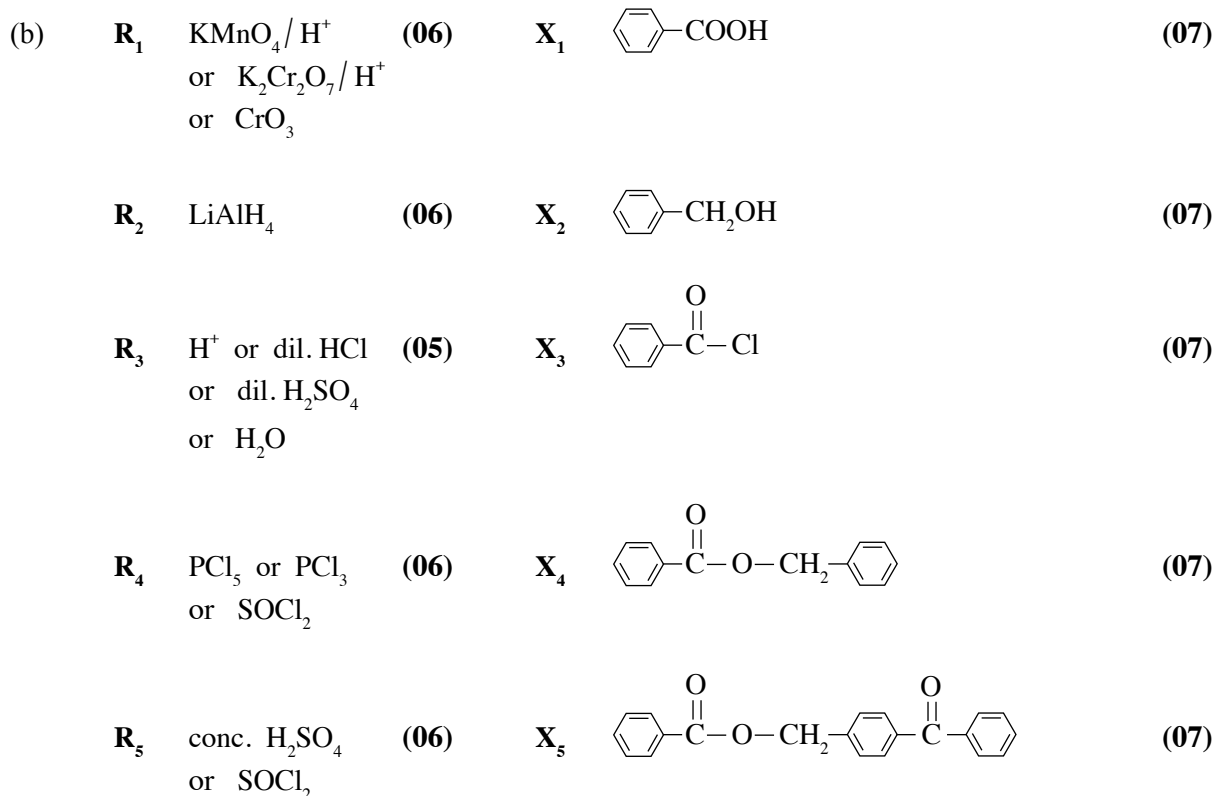

7(a) : 60 marks

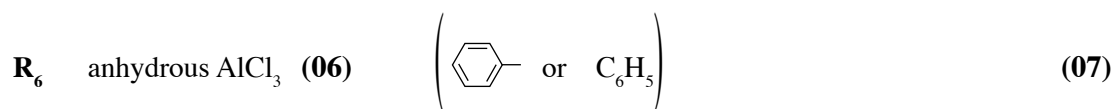



Note : For X₁ to X₄, if  is given instead of  penalize only once.
For X₅, all aromatic rings must be shown for award of marks.

7(b) : 70 marks

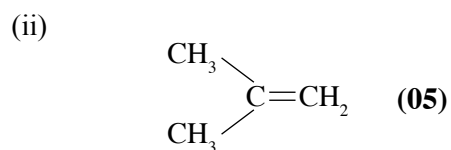
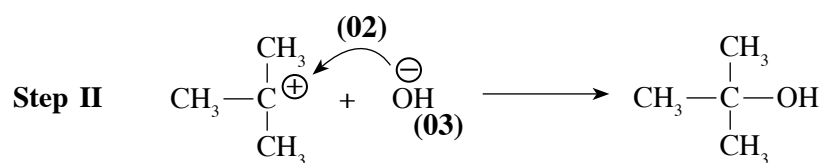
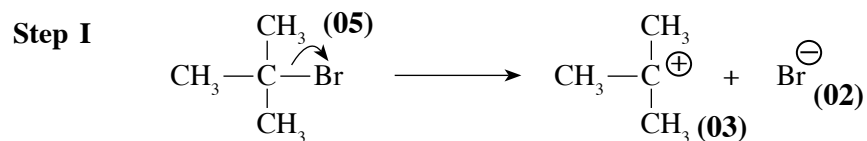
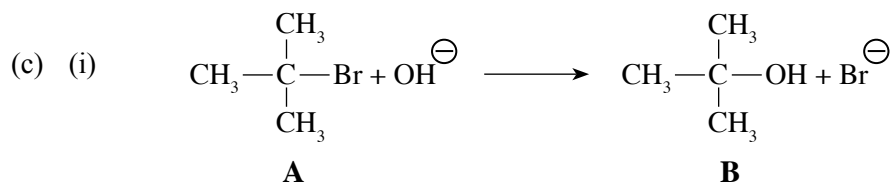

7(c) : 20 marks

Total for 7 : 150 marks

Question 8

8. (a) The compound **A** ($A = MX_n$, $M =$ a transition element that belongs to the $3d$ -block, $X =$ ligands of the same type) when treated with excess dilute NaOH followed by H_2O_2 gives a compound **B**. When an aqueous solution of **B** is acidified with dil. H_2SO_4 compound **C** is produced. **C** when reacted with NH_4Cl gives compound **D** as one of the products. Heating solid **D** gives a blue coloured compound **E**, water vapour and an inert diatomic gas **F**. Ca metal when burnt in gas **F** gives a white solid **G**. The reaction of **G** with water liberates a gas **H**. This gas forms white fumes with HCl gas. The metal Na reacts with liquid **H** to give a colourless diatomic gas **I** as one of the products. When an aqueous solution of **A** is treated with excess Na_2CO_3 , a coloured precipitate is formed. The precipitate is filtered and the filtrate is acidified with dil HNO_3 . Addition of $\text{AgNO}_3(\text{aq})$ to this solution gives a white precipitate which is soluble in dilute NH_4OH .
- Identify **A**, **B**, **C**, **D**, **E**, **F**, **G**, **H** and **I**.
 - What will you observe when a solution containing **C** is treated with dil. NaOH ? Give the balanced chemical equation relevant to this observation.

- (b) An aqueous solution **T** contains **three** metal ions. The following experiments were carried out to identify these metal ions.

Experiment	Observation
1. T was acidified with dilute HCl , and H_2S was bubbled through the clear solution obtained.	A black precipitate Q_1 was formed.
2. Q_1 was removed by filtration. The filtrate was boiled till all the H_2S was removed. The solution was cooled, and NH_4Cl and NH_4OH were added. H_2S was bubbled through the solution.	A clear solution was obtained. A black precipitate Q_2 was formed.
3. Q_2 was removed by filtration. The filtrate was boiled till all the H_2S was removed, and a solution of $(\text{NH}_4)_2\text{CO}_3$ was added.	A white precipitate Q_3 was formed.

Experiments for precipitates Q_1 , Q_2 and Q_3 .

Experiment	Observation
1. Q_1 was dissolved in hot dilute HNO_3 . After cooling, the solution was neutralized and KI was added.	A precipitate and a brown solution were formed.
2. Q_2 was dissolved in warm dilute HCl . The solution was cooled, and dilute NH_4OH was added. More dilute NH_4OH was added to this mixture.	A green precipitate was formed. The green precipitate dissolved giving a deep blue solution.
3. Q_3 was dissolved in conc. HCl and the solution was subjected to the flame test.	A green flame was obtained.

- Identify the **three** metal ions in solution **T**. (**Reasons are not required.**)
 - Write the chemical formulae of the precipitates Q_1 , Q_2 , and Q_3 .
- (c) The following procedure was used to determine the concentration of Al^{3+} ions in solution **U**.

Excess 8-hydroxyquinoline (commonly known as oxine, , $\text{C}_9\text{H}_7\text{ON}$) was added to 25.0 cm^3 of solution

U at $\text{pH} = 5$ to precipitate Al^{3+} ions as aluminium oxinate, $\text{Al}(\text{C}_9\text{H}_6\text{ON})_3$. The precipitate was filtered, washed with distilled water and dissolved in warm dilute HCl containing excess KBr . Thereafter, 25.0 cm^3 of $0.025 \text{ mol dm}^{-3}$ KBrO_3 was added to this solution. The reactions taking place in the above procedure are as follows:

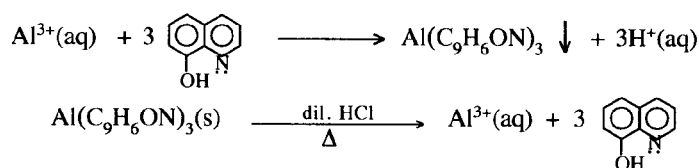

KBrO₃ is a primary standard for the generation of Br₂ in acidic medium.

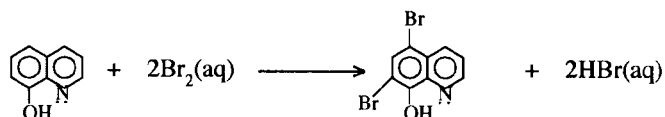
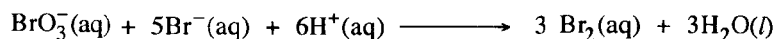

The excess Br₂ is reacted with KI to give I₃⁻. Then I₃⁻ was titrated with 0.05 mol dm⁻³ Na₂S₂O₃ using starch as the indicator. The volume of Na₂S₂O₃ required to reach the end point was 15.00 cm³.

Calculate the concentration of Al³⁺ in solution U in mg dm⁻³. (Al = 27)

8. (a) (i) A : CrCl₃ **or** CrCl₃.H₂O **or** [Cr(H₂O)₆]3Cl⁻
 B : Na₂CrO₄
 C : Na₂Cr₂O₇
 D : (NH₄)₂Cr₂O₇
 E : Cr₂O₃ (Award (05) for any chromium compound)
 F : N₂
 G : Ca₃N₂
 H : NH₃
 I : H₂

(05 × 9 = 45 marks)

(ii) Orange solution C turns yellow

(01 + 01)



(03)

8(a) : 50 marks

(b) (i) T Contains : Cu²⁺, Ni²⁺, Ba²⁺

(10 + 10 + 10)

(ii) Q₁ : CuS Q₂ : NiS Q₃ : BaCO₃

(07 + 07 + 06)

Note : (i) charges are required. (ii) mark independently.

8(b) : 50 marks

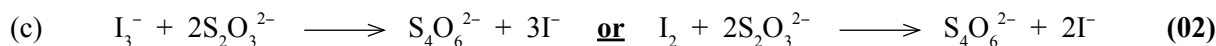

$$\text{Moles of S}_2\text{O}_3^{2-} = \frac{0.05}{1000} \times 15.0 \quad (03)$$

$$\text{Therefore, moles of I}_2 = \frac{1}{2} \times \frac{0.05}{1000} \times 15.0 \quad (03)$$

PAPERMASTER.LK

$$\text{Therefore, moles of excess Br}_2 = \frac{1}{2} \times \frac{0.05}{1000} \times 15.0 \quad (03)$$

$$= 3.75 \times 10^{-4} \quad (02)$$

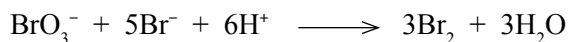

$$\text{Moles of BrO}_3^- = \frac{0.025}{1000} \times 25.0 \quad (03)$$

Therefore, moles of Br₂ produced by the above reaction

$$= 3 \times \frac{0.025}{1000} \times 25.0 \quad (03)$$

$$= 18.75 \times 10^{-4} \quad (02)$$

$$\text{Amount of Br}_2 \text{ reacted with oxine} = (18.75 \times 10^{-4}) - (3.75 \times 10^{-4}) \quad (03)$$

$$= 15 \times 10^{-4} \quad (02)$$

$$\text{Therefore, moles of oxine} = \frac{1}{2} \times 15 \times 10^{-4} \quad (03)$$

$$= 7.5 \times 10^{-4} \quad (02)$$

$$\text{Therefore, moles of Al}^{3+} = \frac{1}{3} \times 7.5 \times 10^{-4} \quad (03)$$

$$= 2.5 \times 10^{-4} \quad (02)$$

$$[\text{Al}^{3+}] = \frac{2.5 \times 10^{-4}}{25.0} \times 1000 \text{ mol dm}^{-3} \quad (03)$$

$$= \frac{2.5 \times 10^{-4}}{25.0} \times 1000 \times 27 \text{ g dm}^{-3} \quad (03)$$

$$= \frac{2.5 \times 10^{-4}}{25.0} \times 1000 \times 27 \times 1000 \text{ mg dm}^{-3} \quad (03)$$

$$= 270 \text{ mg dm}^{-3} \quad (03)$$

8(c) : 50 marks

Total for 8 : 150 marks

Question 9

9. (a) A flow chart drawn by a final year university student to establish a chemical industry in the future in Sri Lanka is given below.

The following symbols are used to represent natural raw materials, manufacturing processes and products.

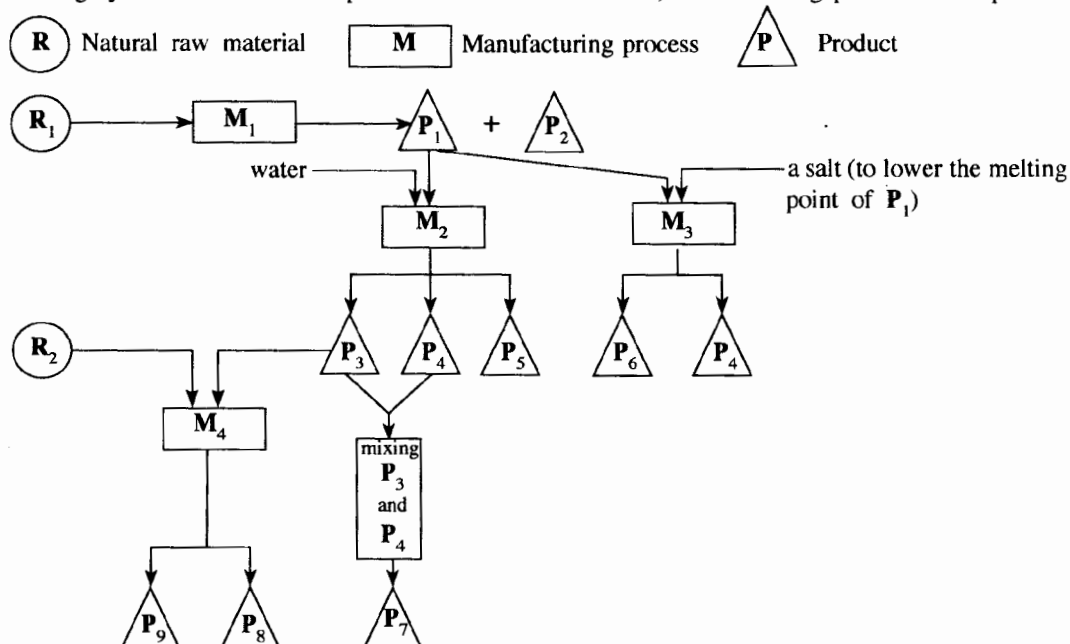

P_2 is used to produce a halogen that exists as a liquid at room temperature.

P_7 is used as a bleaching agent/strong oxidizing agent.

P_8 is used daily to maintain good hygiene.

- (i) Identify the **two** natural raw materials R_1 and R_2 .
 - (ii) Identify the **four** manufacturing processes M_1 , M_2 , M_3 and M_4 [e.g. manufacture of ammonia or Haber process]
 - (iii) Identify the products P_1 to P_9 .
 - (iv) Briefly describe the steps involved in processes M_1 and M_3 . (diagrams of equipment **not** required.)
 - (v) Draw and label the equipment used in the process M_2 .
 - (vi) Identify the salt used in the process M_3 .
 - (vii) Give **one** use for each of P_5 , P_6 and P_9 .
- (b) Answer these questions using the list given below.
- CO_2 , CH_4 , volatile hydrocarbons, NO, NO_2 , N_2O , NO_3^- , SO_2 , H_2S , CFC, $CaCO_3$, liquid petroleum and coal
- (i) Identify **two** gaseous species that are responsible for acid rain and briefly explain, with the aid of balanced chemical equations, how these species cause acid rain.
 - (ii) Acid rain has harmful effects on the environment. Briefly discuss this statement
 - (iii) Identify **three** species that are emitted to the environment due to the burning of fossil fuel, along with one adverse environmental issue for each.
 - (iv) "The existence of trace amounts of industrial synthetic species in the atmosphere can cause adverse environmental issues." Explain this statement using CFC as an example.
 - (v) Identify **five** greenhouse gases and state a human activity by which each of these gases enters the atmosphere.
 - (vi) Briefly explain using balanced chemical equations, how a natural substance (select from the list) can be used to remove acidic gases emitted during the burning of fossil fuel.

9. (a) (i) R_1 : Sea water (03)
 R_2 : Oil / Fats / Coconut oil / Vegetable oil (03)
- (ii) M_1 : Manufacture of salt (03)
 M_2 : Manufacture of NaOH (03)
 M_3 : Manufacture / extraction of Na (Downs cell method) (03)
 M_4 : Manufacture of soap (03)
- (iii) P_1 : NaCl (03)
 P_2 : Bittern solution / Mother liquor / $MgBr_2$ (03)
 P_3 : NaOH (03)
 P_4 : Cl_2 (03)
 P_5 : H_2 (03)
 P_6 : Na (03)
 P_7 : NOCl / Milton solution (03)
 P_8 : Soap (03)
 P_9 : Glycerol / Glycerine (03)

(iv) **Process M_1**

Sea water evaporated in three tanks (01)

1st tanks : $CaCO_3$ precipitates (01) Remaining solution transferred to 2nd tank. (01)

2nd tank : $CaSO_4$ precipitates (01) Remaining solution transferred to 3rd tank. (01)

3rd tank : NaCl precipitates (01) Remaining solution (Bittern) is removed. (01)

Note : Explanation could be given as a diagram.

Process M_3

Electrolysis of molten NaCl with added $CaCl_2$ (01)

At the cathode $Na^+(l) + e \longrightarrow Na(l)$ (02)

At the anode $2Cl^-(l) \longrightarrow Cl_2(g) + 2e$ (02)

Cathode and anode are separated by a steel gauze diaphragm to prevent Na from reacting with Cl_2 gas (02)

Note : Physical states are required in equations.

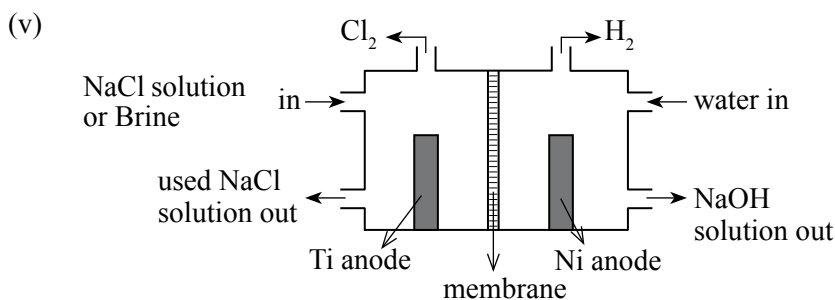

Note : Mark independently.

(01 marks \times 9 + 01 for correct sketch of cell = 10 marks)

Alternate answer :

Diaphragm Cell

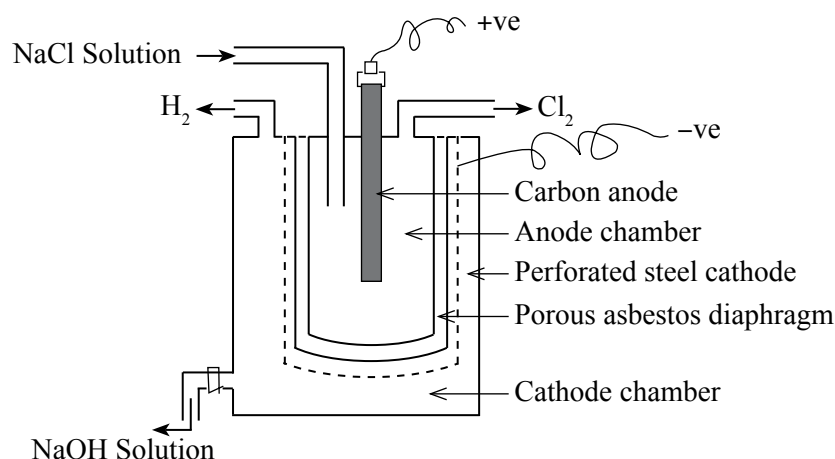

(01 marks × 9 + 01 for correct sketch of cell = 10 marks)

(vi) CaCl_2 (03)

(vii) P_5 : fuel / to manufacture HCl / to manufacture margarine / in weather balloons/ manufacture of NH_3 (01)

P_6 : Sodium vapour lamps/ synthesis of NaNH_2 / to dry organic solvents / as a coolant in nuclear reactors (01)

P_9 : to manufacture cosmetics / to manufacture TNG (explosives) (01)

9(a) : 75 marks

(b) (i) $\text{NO}_2, \text{SO}_2, \text{NO}$ (02 + 02)

From NO :

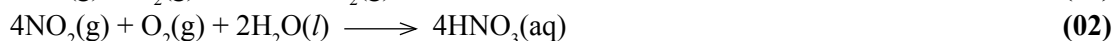

From NO_2 :

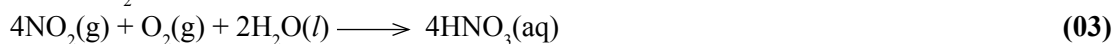

From SO_2 :



or

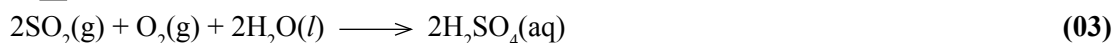

(Generation of acid rain by any two sets of reactions given above, 05 marks × 2 = 10marks)

Note : Physical states are not required.

(ii) Points to be included :

- Damage to plants
- $\text{HNO}_3/\text{H}_2\text{SO}_4$ dissolves aluminosilicates on Earth to give free Al^{3+} which leaches into water and interferes with the operation of fish gills resulting in the death of fish.
- Washes out nutrients from soil
- Degrades metallic structures (e.g. vehicles, bridges, buildings, statues)
- Hardness of water increases
- Concentration of heavy metals in water increases
- Composition of Earth's surface changes (e.g. due to solubility of dolomite, limestone, marble, sand and rock /oxidation of minerals such as sulfides)

Any five (02 marks × 5 = 10 marks)

(iii) SO_2 , NO, NO_2 , CO_2 , Volatile hydrocarbons **(any three)** **(02 + 02 + 02)**

Global warming - CO_2 , Volatile hydrocarbons **(02 + 01)**

Acid rain - SO_2 , NO **(02 + 01)**

Photochemical smog - NO, hydrocarbons **(02 + 01)**

- (iv) • CFCs are industrial gases that are used as coolants in refrigerators, air conditioners and spray cans.
- CFCs are released into the atmosphere during usage and repair of these equipment.
 - CFCs are highly stable trace gasses in the atmosphere.
 - Therefore, CFCs are persistent gasses in the atmosphere.

and

- CFCs produce in the higher atmosphere (stratosphere) in the presence of high energy UV radiation.
- The increases the rate of depletion of ozone by acting as a catalyst.
- The reduction of ozone allows harmful UV rays to reach the surface of the planet.
- Exposure to harmful UV radiation results in cancers, gene mutations and cataracts.

or

- CFC is a strong greenhouse gas.
- CFCs contribute to global warming.
- CFCs absorb IR radiation emitted from the surface of the planet.
- Global warming results in climate change.

(02 × 8 = 10 marks)

- (v) CO₂ : (fossil) fuel burning (01 + 01)
- CH₄ : wet land agriculture/ animal farms/ improper waste disposal (01 + 01)
- NO₂ : Burning at high temperatures (01 + 01)
- CFCs : air conditioners/ refrigerators/ spray guns (01 + 01)
- N₂O : agriculture (use of nitrogen fertilizer) (01 + 01)
- H₂S : Anaerobic digestion of sulfur containing substances such as coconut husks (01 + 01)
- SO₂ : fossil fuel burning (01 + 01)
- Volatile hydrocarbons – fossil fuel burning , natural gas extraction, transportation (01 + 01)
- Any five (02 × 5 = 10 marks)**

- (vi) Limestone (CaCO₃) decomposes to get CaO (lime) and CO₂. (02)
- $$\text{CaCO}_3 \xrightarrow{\Delta} \text{CaO} + \text{CO}_2 \quad (03)$$
- CaO then reacts with the SO₂ (02)
- $$\text{CaO} + \text{SO}_2 \longrightarrow \text{CaSO}_3 \quad (03)$$

Note : If only equation is given 05 marks

or

- Slurry of lime stone is used to absorb or scrub SO₂. (05)
- $$\text{CaCO}_3 + \text{SO}_2 \longrightarrow \text{CaSO}_3 + \text{CO}_2 \quad (05)$$

9(b) : 75 marks

Total for 9 : 150 marks

Question 10

10. (a) **X, Y and Z** are coordination compounds. They have an octahedral geometry. The atomic composition of the species in the coordination sphere (i.e. metal ion and the ligands coordinated to it) in **X, Y and Z** are $\text{FeH}_{10}\text{CNO}_5\text{S}$, $\text{FeH}_8\text{C}_2\text{N}_2\text{O}_4\text{S}_2$ and $\text{FeH}_6\text{C}_3\text{N}_3\text{O}_3\text{S}_3$ respectively. The oxidation state of the metal ion in all three compounds is the same. In each compound, **two types** of ligands are coordinated to the metal ion. If these compounds contain **non-coordinated** anions, they are of the same type.

An aqueous solution **S** contains **X, Y and Z** in the molar ratio 1:1:1. The concentration of **each** compound in solution **S** is 0.10 mol dm^{-3} . When excess AgNO_3 solution was added to 100.0 cm^3 of **S**, a yellow precipitate was formed. The precipitate was washed with water and oven dried to a constant mass. The mass of the precipitate was 7.05 g . This precipitate does not dissolve in conc. NH_4OH .

(Relative molecular mass of the chemical compound in the yellow precipitate = 235)

- Identify the ligands coordinated to the metal ions in **X, Y and Z**.
- Write the chemical formula of the yellow precipitate.
- Giving reasons, determine the structures of **X, Y and Z**.
- Given below is the structure of ethylenediamine (en)

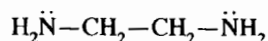

Ethylenediamine coordinates to the metal ion M^{3+} through the two nitrogen atoms, to form the complex ion **Q** (i.e. metal ion and ligands coordinated to it). **Q** has an octahedral geometry.

Write the structural formula of **Q** and draw its structure.

Note: Consider that only ethylenediamine is coordinated to the metal ion. Use the abbreviation 'en' to denote ethylenediamine in your structural formula.

- (b) You are provided with the following.

- 1.0 mol dm^{-3} aqueous solutions of $\text{Al}(\text{NO}_3)_3$, $\text{Cu}(\text{NO}_3)_2$ and $\text{Fe}(\text{NO}_3)_2$
- Al, Cu and Fe metal rods
- Chemicals required to use in salt bridges
- Conducting wires and beakers

In addition to the above, the following data is also provided.

$$E_{\text{Fe}^{2+}/\text{Fe}}^{\circ} = -0.44 \text{ V}, \quad E_{\text{Al}^{3+}/\text{Al}}^{\circ} = -1.66 \text{ V}, \quad E_{\text{Cu}^{2+}/\text{Cu}}^{\circ} = +0.34 \text{ V}$$

- Diagram the **three** electrochemical cells that can be constructed using the above materials. Indicate the anode and cathode along with their signs in each cell.
- For each electrochemical cell drawn in part (i) above
 - give the cell notation.
 - determine E_{cell}° .
 - give balanced chemical equations with physical states for the electrode reactions.
- Giving reasons, explain which of the following compounds is/are appropriate to use in salt bridges.
 NaOH , NaNO_3 , acetic acid
- Consider the electrochemical cell which shows the highest E_{cell}° initially. Assume that this electrochemical cell has been constructed using equal volumes of the relevant solutions in each compartment and their volumes do not change during the experiment.

The two electrodes of this cell were connected using a conducting wire and after some time, the concentration of metal ions in the anode compartment was found to be $C \text{ mol dm}^{-3}$. Express the concentration of metal ions in the cathode compartment in terms of **C**.

10.(a) (i) $\text{SCN}^- / \text{NCS}^-$ and H_2O (05 + 05)

(ii) AgI (05)

(iii) Based on the atomic composition;

coordination sphere of X : $[\text{Fe}(\text{H}_2\text{O})_5(\text{SCN})]$ or $[\text{Fe}(\text{SCN})(\text{H}_2\text{O})_5]$ (05)

coordination sphere of Y : $[\text{Fe}(\text{H}_2\text{O})_4(\text{SCN})_2]$ or $[\text{Fe}(\text{SCN})_2(\text{H}_2\text{O})_4]$ (05)

coordination sphere of Z : $[\text{Fe}(\text{H}_2\text{O})_3(\text{SCN})_3]$ or $[\text{Fe}(\text{SCN})_3(\text{H}_2\text{O})_3]$ (05)

Note: (NCS) could be used instead of (SCN). Could be written as either H_2O or OH_2 .

Number of moles of each compound (i.e. X, Y, Z) in $100 \text{ cm}^3 = (0.1/1000) \times 100$
 $= 0.01$ (05)

Relative molecular mass of AgI $= 235$

Therefore, number of moles of AgI (or I⁻) in the precipitate $= 7.05/235 = 0.03$ (05)

If oxidation state of Fe is +3 ;

X : Charge of complex is +2. Hence, two I⁻. (02)

Y : Charge of complex is +1. Hence, one I⁻. (02)

Z : Complex has no charge. Hence, no I⁻. (02)

Therefore, oxidation state of Fe has to be +3. (04)

or

If oxidation state of Fe is +2;

X : Charge of complex is +1. Hence, one I⁻. (02)

Y : Charge of complex is zero. Hence, will not have any I⁻. (02)

Z : Charge of complex is -1. Hence, will not have any I⁻. (02)

Therefore, oxidation state of Fe cannot be +2. It has to be +3. (04)

Structural formulae:

X : $[\text{Fe}(\text{H}_2\text{O})_5(\text{SCN})]\text{I}_2$ or $[\text{Fe}(\text{SCN})(\text{H}_2\text{O})_5]\text{I}_2$ (05)

Y : $[\text{Fe}(\text{H}_2\text{O})_4(\text{SCN})_2]\text{I}$ or $[\text{Fe}(\text{SCN})_2(\text{H}_2\text{O})_4]\text{I}$ (05)

Z : $[\text{Fe}(\text{H}_2\text{O})_3(\text{SCN})_3]$ or $[\text{Fe}(\text{SCN})_3(\text{H}_2\text{O})_3]$ (05)

Note:

- (NCS) could be used instead of (SCN). No marks for (CNS) / CSN). H_2O could be written as OH_2 .
- If the coordination spheres of X, Y, Z are not written but the structural formulae of X, Y, Z are written, award the (05 + 05 + 05) for the correct structural formulae and the marks allocated for the respective coordination sphere (05 + 05 + 05).

(iv) $(M(en)_3)^{3+}$

(05)

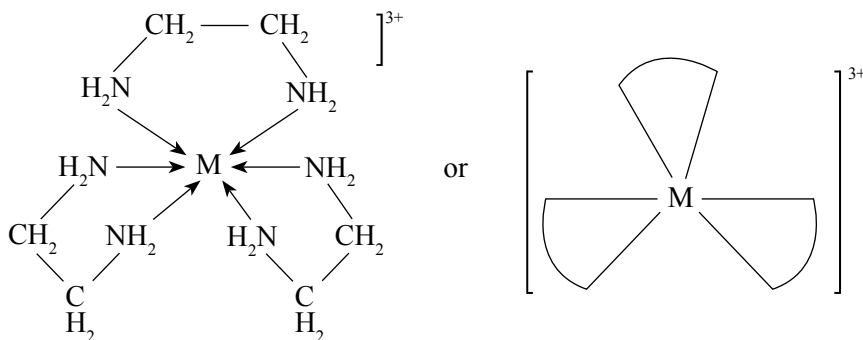

Note : Charge of the complex is required for the award of marks.

10(a) : 75 marks

(b) (i)

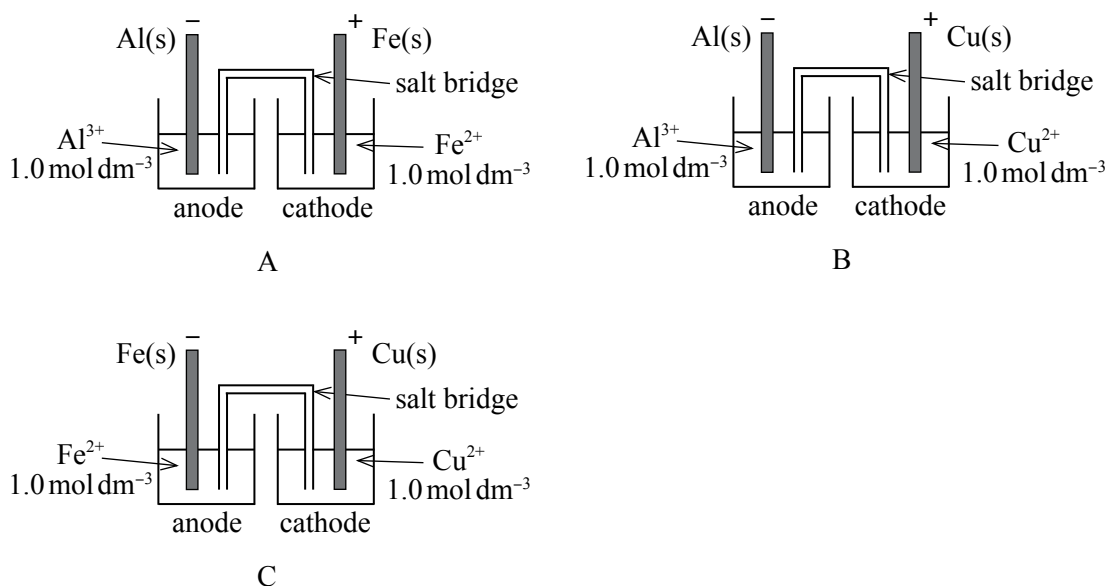

For each electrode;

- Display and identification of metal strip (01)
- Identification of the solution (01)
- Display of correct charge (01)
- Correct labeling as anode or cathode (01)
- Display of the salt bridge (01)

Note : Mark each electrode individually, If a voltmeter is drawn, do not deduct marks.
If a battery or an external voltage source is connected, do not award marks.
If the electrodes are connected by a wire deduct 02 marks.

(27 marks for 3 cells)

- (ii) I. Cell A : $\text{Al(s)} | \text{Al}^{3+}(\text{aq}, 1.0 \text{ mol dm}^{-3}) || \text{Fe}^{2+}(\text{aq}, 1.0 \text{ mol dm}^{-3}) | \text{Fe(s)}$ (02)
 Cell B : $\text{Al(s)} | \text{Al}^{3+}(\text{aq}, 1.0 \text{ mol dm}^{-3}) || \text{Cu}^{2+}(\text{aq}, 1.0 \text{ mol dm}^{-3}) | \text{Cu(s)}$ (02)
 Cell C : $\text{Fe(s)} | \text{Fe}^{2+}(\text{aq}, 1.0 \text{ mol dm}^{-3}) || \text{Cu}^{2+}(\text{aq}, 1.0 \text{ mol dm}^{-3}) | \text{Cu(s)}$ (02)

II. $E_{\text{cell}}^0 = E_{\text{cathode}}^0 - E_{\text{anode}}^0$ $E_{\text{cell}}^0 = E_{\text{RHS}}^0 - E_{\text{LHS}}^0$ (03)

Cell A

$E_{\text{cell}}^0 = -0.44 \text{ V} - (-1.66 \text{ V})$ (02)
 $= 1.22 \text{ V}$ (01 + 01)

Cell B

$E_{\text{cell}}^0 = 0.34 \text{ V} - (-1.66 \text{ V})$ (02)
 $= 2.00 \text{ V}$ (01 + 01)

Cell C

$E_{\text{cell}}^0 = 0.34 \text{ V} - (-0.44 \text{ V})$ (02)
 $= 0.78 \text{ V}$ (01 + 01)

- III. Cell A : $\text{Al(s)} \rightleftharpoons \text{Al}^{3+}(\text{aq}) + 3\text{e}$ (01)
 $\text{Fe}^{2+}(\text{aq}) + 2\text{e} \rightleftharpoons \text{Fe(s)}$ (01)

- Cell B : $\text{Al(s)} \rightleftharpoons \text{Al}^{3+}(\text{aq}) + 3\text{e}$ (01)
 $\text{Cu}^{2+}(\text{aq}) + 2\text{e} \rightleftharpoons \text{Cu(s)}$ (01)

- Cell C : $\text{Fe(s)} \rightleftharpoons \text{Fe}^{2+}(\text{aq}) + 2\text{e}$ (01)
 $\text{Cu}^{2+}(\text{aq}) + 2\text{e} \rightleftharpoons \text{Cu(s)}$ (01)

Note : Do not award marks if \longrightarrow is used instead of \rightleftharpoons Physical states are required.

- (iii) NaOH - not suitable, metal hydroxides can be formed. (02)
 NaNO₃ - suitable, good ionic conductivity OR (02)
 (not suitable because ionic conductivities of Na⁺ and NO₃⁻ are different)
 Acetic acid - not suitable, weakly ionized, low conductivity (02)

Alternate answer - 1

- None of the given compound is suitable. (03)
 NaOH - metal hydroxide can be formed (01)
 NaNO₃ - mobility / conductivity of two ions are different (01)
 Acetic acid - weakly ionized / low conductivity (01)

Alternate answer - 2

- Only NaNO₃ is suitable (03)
 Due to its good ionic conductivity, does not participate in electrode reactions (03)

(iv) Selection of the correct pair of electrodes (03)

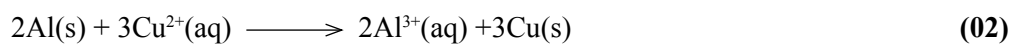

(Physical states and stoichiometry must be correct.)

Initial (mol dm ⁻³)	1.0	1.0	
After time, t (mol dm ⁻³)	(1 - 3x/V)	(1 + 2x/V)	
Where V= Volume		(02)	(02)

$$[\text{Al}^{3+}] = 1 + 2x/V = c \quad (03)$$

$$x/V = (c - 1)/2$$

$$[\text{Cu}^{2+}] = 1 - 3(c - 1)/2 \quad (03)$$

$$= (5 - 3c)/2$$

or

Selection of the correct pair of electrodes (03)

Assume the concentration of [Al³⁺] increased during time t = c₁ mol dm⁻³

$$\text{Then } [\text{Al}^{3+}] = 1 + c_1 = c \quad (03)$$

$$\text{Concentration of } [\text{Cu}^{2+}] \text{ increased during time} = 3c_1/2 \text{ mol dm}^{-3} \quad (03)$$

$$\text{Therefore } [\text{Cu}^{2+}] = 1 - 3c_1/2 \quad (03)$$

$$= 1 - 3(c - 1)/2 \quad (03)$$

$$= (5 - 3c)/2$$

10(b) : 75 marks

Total for 10 : 150 marks

Part III

3 Facts to be considered when answering questions and suggestions :

3.1. Facts to be considered when answering :

Common instructions :

- * The candidates should read and understand well the basic instructions given in the question paper. They should be considerate as to the facts such as how many questions be answered in each section, which questions are compulsory, what time is affordable and how much marks are allocated. They should also read the questions carefully and select the questions with a clear mind set.
- * When responding to the questions in Paper I, one option which is the most correct needs to be selected. Also, one cross must be placed clearly.
- * When answering questions in Paper II, every new question should be started in a new page.
- * Answers should be written in clear and correct handwriting.
- * The candidate's` index number should be written on every page in the relevant box.
- * Numbers of questions, parts and sub parts should be indicated correctly.
- * Long descriptions shouldn't be given when short specific answers are expected. Similarly short answers should be avoided in places where descriptive answers are preferred.
- * According to the way the question is posed, facts should be presented logically and analytically.
- * When answering paper II, all the sub parts given under the main question should be read carefully and only the target answer relevant to each sub part should be presented.
- * Care should be taken to manage time properly when answering questions.
- * Candidates should use blue or black pens to write answers and should avoid using red and green pens.
- * When the bell starts ringing indicating that the time set apart for writing is about to be over, all the answer scripts should be arranged and tied up properly.
- * In order to manage time more effectively, it is better to answer the easier questions first and then more difficult ones rather than answering them in the given sequence.

Special instructions :

Generally when consider the principles of the subject based on which the questions set in paper I and II and when analyze the selection of responses in paper I by the students, following suggestions can be introduced to uplift the competency level of the students.

For the area of organic chemistry special attention should be paid on the following facts.

- * Studying comparatively on the different products formed by the reduction of 'N' containing compounds by LiAlH_4 and NaBH_4 .
- * Studying comparatively on the reactions done by Grignard reagent with esters and alkynes containing acidic hydrogen.
- * Illustrating suitable examples for clear understanding of the words such as enantiomers and diastereomers related to the concept isomerism.
- * Clearly understanding the variation of the acidity of the organic compounds containing different functional groups such as $-\text{COOH}$, , $-\text{CH}_2\text{OH}$.
- * Drawing the structure of the organic compounds containing more than one functional groups and explaining their three-dimensional existence.
- * When identifying the organic compounds using various reagents in the reactions, asking students not only to pay attention on the observations but also to write the appropriate chemical equations. For examples reactions done with Brady's reagent, Fehling's reagent and Tollen's reagent.
- * Instead of by-hearting the organic mechanisms giving a better explanation on transferring of electrons, breaking bonds, forming bonds, steric-effects by three-dimensional models etc.

For the area of physical chemistry special attention should be paid on the following facts.

- * When solving the problems using chemical equations those should be correctly balanced in accordance with the stoichiometric ratio, write the physical states of reactants/products and use the relevant chemical principles and practice the way to get the correct answer by doing more exercises considering all those facts together.
- * Always when using physical parameters along with their numerical values stating the correct units and converting the units correctly.
- * Solving problems containing both symbols as well as numerical values.
- * Solving problems related to logarithm and anti-logarithm.
- * Giving correct understanding about extensive properties and intensive properties.

- * Avoiding the difficulty in constructing the mutual relationship between the chemical principles.

Examples :

- Equilibrium and rate of reactions
- ΔH , ΔS , ΔG and spontaneity of reactions
- Chemical reactions and phase equilibrium
- Le Chatelier's principle and its applications
- Structures of the organic compounds, functional groups, knowledge of polarity using in the calculations such as distribution coefficient

For the area of General/ Inorganic/ Industrial and Environmental Chemistry special attention should be paid on the following facts.

- * When analyzing the data obtained from practical experiments developing the ability of illustrating those by appropriate reactions and balanced chemical equations.

Examples :

- Reactions forming coloured compounds / complexes
- Identification reactions

- * Developing the knowledge on reactions, colour and the oxidation number of the central atom in inorganic co-ordinate complexes.

- * Focusing attention on the correct steps to be followed in drawing the Lewis structures and resonance structures. (lone pair electrons, formal charges etc.)

- * Giving better knowledge on the variation of the bond angles related to the electron pair repulsion and electro-negativity.

Examples :

- NH_3 and NF_3
- H_2O and H_2S

- * Making them understand the relationship between the stability of the ions and the electron configuration.

3.2. Comments and suggestions about the teaching learning process :

- * As the ability answering questions related to practical activities is generally low, students should be engaged in practical activities during the learning teaching process.
- * Principles should be tried to teach as nature of models in Chemistry to be highlighted.
- * Students are not required to by heart all the concepts in chemistry but they should be oriented to solve problems applying them correctly at relevant instances.
- * Since a large number of compounds are studied under organic chemistry more attention should be paid for the preparation of short notes creatively and work out suitable exercises.
- * When writing mechanisms for organic reactions students need to practice the correct method along with correct usage of symbols.
- * When explaining concepts in chemistry, suitable learning teaching methods and equipment should be used to facilities understanding.
- * In every possible instance of the learning teaching process, the concepts need to be related to the day to day living in a practical perspective.
- * A greater attention of students should be drawn to the sections newly introduced to the syllabus.
- * Exercises should be done following the common method of solving problems correctly. First the problem should be studied and the shortest route to be taken to get the correct answer should be stressed.
- * Since the achievement level of the last units of the syllabus is relatively low, the learning teaching process should be geared to draw more attention towards them.
- * Modern technology should be used in the teaching-learning process and accessing of internet gives the chance for proper studying of the subject matter related to practical chemistry.
- * In the projects done under the school based assessments, it is required to pay attention on the things related to the subject .